

Congratulations on your purchase of the **Big Gulp 3500®** unit. This instruction/parts manual is a guide for operating and servicing your **DRI-EAZ** unit.

Proper operation and service are necessary to ensure the outstanding performance of this unit. When properly maintained, your extraction unit will have a long and trouble free life.

The following service methods outlined in this manual are detailed in a manner that operation and servicing may be performed properly and safely. Because service levels vary due to the skill of the mechanic, tools and parts availability, ensure that prior to attempting any repair, you are familiar with this equipment and have the proper tools. Any questions regarding the operation, service, or repair of this unit should be directed to your nearest dealer.

The headings **WARNING** and **CAUTION** are utilized to warn you that steps must be taken to prevent personal injury or damage to the equipment. Please make sure that you have read and understand these instructions entirely before proceeding with the operation of this unit.

THIS UNIT MUST BE INSTALLED BY THE DEALER THAT YOU PURCHASED IT FROM IN ACCORDANCE WITH THE DRI-EAZ INSTALLATION PROCEDURES.

PLEASE ENSURE THAT THE WARRANTY CARD IS FILLED OUT BY THE INSTALLATION SERVICE CENTER THAT INSTALLED THIS UNIT AND IS RETURNED TO **DRI-EAZ**.

Record the serial number of your unit here for future reference or if you should need to contact the factory in the future for any reason.

S/N:

This service and operations manual is written specifically for **Big Gulp 3500®** extraction units manufactured by:

DRI-EAZ

2604 Liberator

Prescott, AZ 86301 USA

The information contained in this document is subject to change without notice and does not represent a commitment on the part of **DRI-EAZ**

All rights reserved. Copyright 2011 by **DRI-EAZ**. No part of this work may be used or reproduced in any form or means without the express written consent and permission of **DRI-EAZ**.

Published by **DRI-EAZ**.
First printing: September, 2011
Revised, August 2012; Rev B
Printed in USA



Big Gulp 3500® MANUAL
PART# 49-080

September 2011

DRI-EAZ LIMITED WARRANTY

DRI-EAZ BIG GULP 3500

What Does This Warranty Cover?

This warranty covers the DRI-EAZ BIG GULP 3500 and is provided to the original purchaser only.

How Long Does This Warranty Last?

This warranty runs for:

- Two (2) years from the date of installation on parts and labor (Excluding normal maintenance items.)
Factory installed original belts are covered for 500 hours. Recovery tank and frame are covered for five years.
All other components including seals, o-rings and electrical components are covered for the entire two year warranty period.

What DRI-EAZ Will Do:

If a defect in materials or workmanship occurs within the warranty period, DRI-EAZ at its election will repair or replace the defective part at no charge.

What This Warranty Does Not Cover:

This warranty does not cover or apply to defects due directly or indirectly to misuse, abuse, disassembly, alteration, corrosive chemicals, improper voltage, improper fuel, fire, flood, negligence, accident, improperly or incorrectly performed maintenance or repair, or failure to perform necessary or recommended maintenance or repair (See your Owner's Manual) or if the use of this product is not in compliance with the instructions and specifications for its use. This warranty does not cover normal maintenance items such as air and oil filters, lubricants and tune up parts. Paint is not covered. Recovery tank and frame are covered for five years.

All other components including seals, o-rings and electrical components are covered for the entire two year warranty period. We limit all implied warranties to:

- Two (2) years from the installation date on parts and labor.

OTHER THAN THE WARRANTIES PROVIDED HEREIN, DRI-EAZ MAKES NO EXPRESS OR IMPLIED, ORAL OR WRITTEN WARRANTIES WITH RESPECT TO THIS PRODUCT OR WORKMANSHIP AND ALL WARRANTIES IMPLIED BY LAW INCLUDING ANY WARRANTIES OF MERCHANTABILITY OR FITNESS FOR A PARTICULAR PURPOSE ARE LIMITED TO THE DURATION OF THIS WARRANTY. **Some states do not allow limitations on how long an implied warranty lasts, so the above limitations may not apply to you.** WE SHALL IN NO EVENT BE LIABLE FOR DEATH, INJURIES TO PERSONS OR PROPERTY OR FOR INCIDENTAL, CONTINGENT, SPECIAL OR CONSEQUENTIAL DAMAGES ARISING FROM USE OF OUR PRODUCTS. **Some states do not allow the exclusion or limitation of incidental or consequential damages, so the above limitation or exclusion may not apply to you.**

How Do I Get Service?

In order to be eligible for service under this warranty you MUST do the following: (a) fill out the warranty registration card on-line within thirty (30) days of the installation of our product; (b) have your dealer write or call for a return material authorization (RMA); and (c) have the serial number and original proof of installation date available.

Proof of proper maintenance may be required before warranty is granted.

Contact us at:

DRI-EAZ
2604 Liberator, Prescott, AZ 86301
Phone: 928-445-3030

If our dealer uncovers a defect we will repair or replace the product, at our election. Ground shipping and transportation costs will be covered by the manufacturer. Returning defective parts to the manufacturer, if required, shall be the responsibility of the purchaser. Warranty may be denied if defective parts are not returned within the allotted 30 days. If it is determined that there is no defect in the product, or that the defect resulted from causes not within the scope of our warranty, then the product will be repaired or replaced only at your request and at your expense and you must bear all shipping costs.

How Does State Law Apply?

This warranty gives you specific legal rights, and you may also have other rights which vary from state to state.

● Table of Contents

| | |
|---|----------|
| SECTION ONE: GENERAL INFORMATION | 1 |
|---|----------|

- 1. SAFETY.....2
Safety, Specifications, Installation, Fuel, Engine Oil
- 2. RECEIVING YOUR EXTRACTION SYSTEM.....7
Dealer Responsibility, Acceptance of Shipment, Equipment Listing, Optional Equipment

| | |
|----------------------------------|----------|
| SECTION TWO: INSTALLATION | 8 |
|----------------------------------|----------|

- 3. INSTALLATION.....9
Lifting the Unit into the Vehicle, Positioning the Unit into the Vehicle, Fastening Down the Unit, Dimensional Diagrams, Installation of Fuel Lines, Trailer Fuel Tank and Fuel Line Installation, Battery Connection, Fire Extinguisher

| | |
|---------------------------------|-----------|
| SECTION THREE: OPERATION | 14 |
|---------------------------------|-----------|

- 4. SYSTEMS.....15
Vacuum System
- 5. OPERATION16
Equipment setup, Instrumentation, Starting Your Unit, Waste Pump, Extraction Process, Shut Down and Daily Maintenance.

| | |
|--|-----------|
| SECTION FOUR: MAINTENANCE and SERVICE | 19 |
|--|-----------|

- MAINTENANCE CHART20
- 6. MAINTENANCE.....21
- 7. GENERAL SERVICE ADJUSTMENTS23
- 8. TROUBLESHOOTING24

| | |
|--|-----------|
| SECTION FIVE: PARTS and ACCESSORIES | 25 |
|--|-----------|

- 9. ILLUSTRATED PARTS LISTINGS.....26
- 10. ACCESSORIES41

SECTION 1: **GENERAL INFORMATION**

1. SAFETY

Safety2
Specifications5
Installation requirements6
Fuel requirements6
Engine oil requirements6

2. RECEIVING YOUR EXTRACTION SYSTEM

Dealer responsibility7
Acceptance of shipment7
Equipment listing7
Optional equipment7

1. SAFETY

WARNING For Your Safety!

The following **WARNING** labels are on your **DRI-EAZ Big Gulp 3500®** console. These labels point out important **WARNINGS and CAUTIONS**, which must be followed at **all** times. Failure to follow warnings could result in personal injury, fatality, to yourself and/or others or property damage. Please follow these instructions carefully!

DO NOT remove these decals.

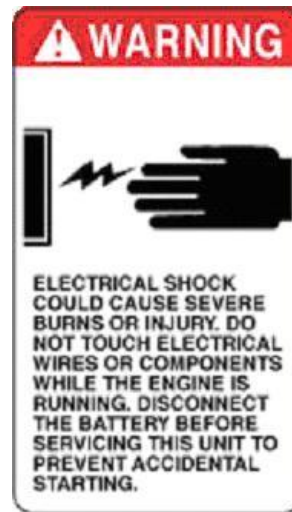
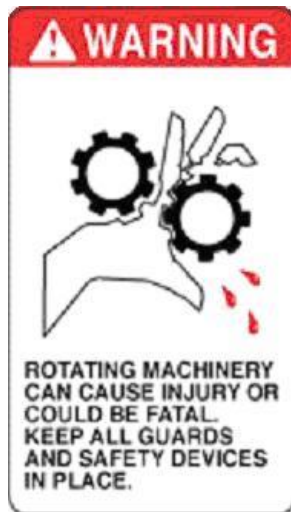

WARNING!

1. Read the operator's manual before starting this unit.

Failure to adhere to instructions could result in severe personal injury or could be fatal.

2. Operate this unit and equipment only in a well ventilated area.

Exhaust fumes contain carbon monoxide, which is an odorless and deadly poison that can cause severe injury or death. **DO NOT** run this unit in an enclosed area. **DO NOT** operate this unit where the exhaust may enter a building doorway, window, vent or other opening.

3. Gasoline is extremely flammable and its vapors can explode if ignited.

Store gasoline only in approved containers, in well ventilated, unoccupied buildings and away from sparks or flames. Never carry gasoline or any flammable materials in the vehicle. Fumes could accumulate inside of the vehicle and ignite, causing an explosion.

4. This unit must be operated with the vehicle doors open in order to ensure adequate ventilation to the engine.

5. DO NOT operate unit if gasoline is spilled. Do not turn ignition switch until the gasoline has been cleaned up. Never use gasoline for cleaning purposes.

6. DO NOT place hands, feet, hair, clothing or any body parts near rotating or moving parts. Rotating machinery can cause severe injury or death.

7. NEVER operate this unit without belt and safety guards. High speed moving parts, such as belts and pulleys, should be avoided while the unit is running. Severe injury, fatality or damage may result.

8. NEVER service this unit while it is running. High speed mechanical parts as well as high temperature components may result in injury or severed limbs.

9. Engine components will be extremely hot from operation. To prevent severe burns, **DO NOT** touch these areas while the unit is running or shortly after the unit is shut off.

10. DO NOT touch any part of the exhaust system while the system is running or for 20 minutes after the unit is shut off. Severe burns could result.

11. NEVER leave the vehicle engine running while the unit is in operation.

12. Battery acid contains sulfuric acid. To prevent acid burns, avoid contact with skin, eyes and clothing. Batteries also produce explosive hydrogen gases while charging. To prevent fire or explosion, charge batteries only in a well ventilated area. Keep sparks, open flames, as well as other sources of ignition away from battery at all times. Remove all jewelry prior to servicing batteries. Keep batteries out of the reach of children.

Before disconnecting the negative (-) ground cable, ensure that all switches are in the off position. If on, a spark could occur at the ground connection terminal which could cause an explosion if hydrogen gas or gasoline vapors are present. **ALWAYS** disconnect the negative (-) terminal first.

13. DO NOT smoke around the machine. Gas fumes could accumulate and ignite. Battery gases are extremely flammable. This will prevent possible explosions.

SECTION 1

14. **DO NOT** damage the vehicle in any way during the installation. When routing fuel lines **DO NOT** configure the hose in any locations where the hose or vehicle could be damaged. Avoid contact with moving parts, areas of high temperature, brake lines, fuel lines, catalytic converters, exhaust pipes, mufflers or sharp objects.

15. **NEVER** cut or splice any of the vehicle fuel lines during fuel line installation. This will result in fuel leaks and potentially dangerous conditions. Use only the provided fuel hose for fuel lines. When going through the vehicle floor with fuel lines, always utilize bulkhead adaptors. This will prevent fuel leaks and ensure that hoses are not punctured by vehicle vibration abrasion.

16. **DO NOT** exceed your vehicles weight limit. The console with waste tank and accessories weighs approximately 900 pounds. Make certain that the vehicle has the correct axle rating. This will prevent unsafe or hazardous driving conditions.

17. High back seats are required for all vehicles that units are to be installed for head and neck protection. Metal partitions between the seats and equipment are strongly recommended.

18. Always keep your vehicle clean and orderly. Wands, tools and accessories must be securely stowed while driving the vehicle.

19. Ensure that you have received proper training from the distributor that you purchased the unit from prior to operation.

20. **DO NOT** modify this unit in any manner. Any modification could result in serious injury or fatality.

**CALIFORNIA PROPOSITION 65
WARNING: ENGINE EXHAUST
FROM THIS PRODUCT CONTAINS
CHEMICALS KNOWN BY THE
STATE OF CALIFORNIA TO CAUSE
CANCER, BIRTH DEFECTS, OR
OTHER REPRODUCTIVE HARM.**

**ALL FUEL LINES MUST MEET
CARB III and EPA PHASE 3 LOW
PERMEABILITY REQUIRMENTS.**

**ALL FUEL STORAGE TANKS MUST
MEET CARB III and EPA PHASE 3
PERMEATION and VENTING
REQUIRMENTS.**

**ALL FUEL ADAPTOR KITS AND
FUEL TANKS USED IN THE STATE
OF CALIFORNIA MUST MEET
CURRENT CALIFORNIA AIR
RESOURCES BOARD (ARB)
REGULATIONS.**

**CARB EXECUTIVE INFORMATION
LABEL(S) MUST BE INSTALLED IN
A VISABLE LOCATION.**

SPECIFICATIONS

| | |
|--|--|
| Engine Speed | 3000 rpm (High Speed No Load) 1500 rpm (Idle No Load) |
| Vacuum Pump RPM | 3380 rpm |
| Vacuum Relief Valve | 14 in. HG |
| Waste Tank Capacity | 100 Gallons at shutoff |
| Console Weight (with waste tank & accessories) | 1000 lbs. |

Use the **Big Gulp** with the **Rover HVE** high volume extractor for maximum water extraction from flooded carpet and pad. The Rover's unsurpassed maneuverability and special features make extraction more efficient than ever. The Rover's joystick precisely controls separate drive wheels to allow easy maneuvering around the sharpest corners. Its patent-pending stainless head with custom polymer glide has a self-healing edge that easily rides over the carpet to maximize extraction on ALL types of carpet. The unit folds flat for easy transport and storage.

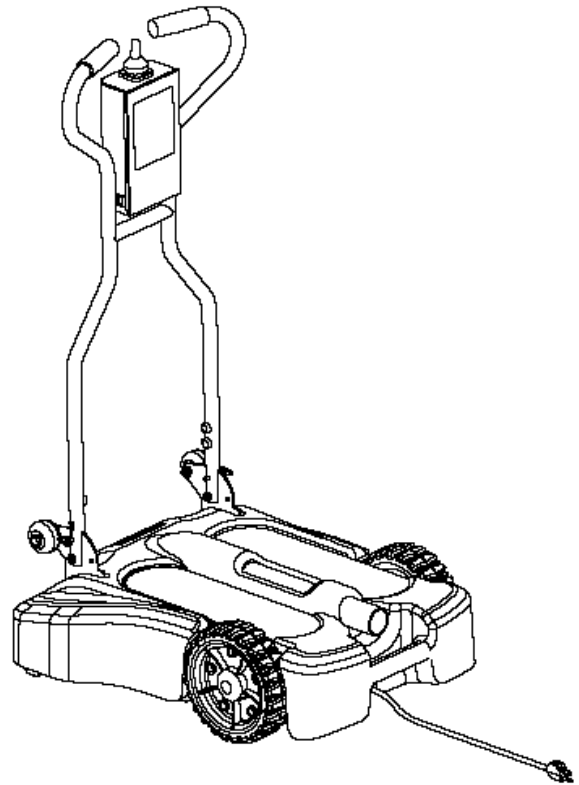

SECTION 1

INSTALLATION REQUIREMENTS

Prior to beginning the installation, read the **ENTIRE “Installation”** section of this manual. Since the **DRI-EAZ Big Gulp 3500®** extraction unit weighs (with accessories) approximately 1000 lbs., please adhere to the following recommendations prior to installing the unit.

1. The unit should **NOT** be installed in any motor vehicle of less than 1 ton capacity.



CAUTION!

The console and waste tank with accessories must NOT exceed the vehicle’s axle weight limit.

2. If mounting the unit in a trailer, ensure that the trailer is rated for the total weight of the **unit and trailer**. Electric or hydraulic brakes must be provided, and strict compliance with all State and Federal laws must be maintained.

3. **DRI-EAZ** recommends using only a **dual axle** trailer. If mounting in a trailer, the **DRI-EAZ Big Gulp 3500®** console must be positioned so that it balances properly with respect to the trailer axles. Ten percent (10%) of the unit’s total overall weight (w/o accessories or water) should be on the tongue. Adequate ventilation with either two sets of doors or a roof ventilation system is highly recommended.

4. The vehicle tires must have a load rating in excess of the combined unit and vehicle weight.

5. **DRI-EAZ** does not recommend using any type of flooring materials that absorb water. This condition will result in rust and corrosion of the vehicle floor.

6. Insulation under rubber mats should be removed prior to installation of the unit.

FUEL REQUIREMENTS

Use unleaded fuel ONLY. NEVER use any gasoline additives. Use only fresh, clean unleaded gasoline intended for normal automotive use. **DO NOT** use high-octane gasoline with this unit.

ENGINE OIL REQUIREMENTS

Use SAE 30 high-quality oil 10W-30 synthetic oil that meets current API (American Petroleum Institute) service classifications. **Do not use additives.**

NOTE: Using a lower service class oil or extending oil change intervals longer than recommended can cause engine damage.

NOTE: Synthetic oils meeting the listed classifications may be used with oil changes performed at recommended intervals. However to allow piston rings to properly seat, a new or rebuilt engine should be operated for at least 50 hours using standard petroleum based oil before switching to synthetic oil.

2. RECEIVING YOUR EXTRACTION SYSTEM

DEALER RESPONSIBILITY

THE DEALER THAT YOU PURCHASED THIS EXTRACTION SYSTEM FROM IS RESPONSIBLE FOR THE PROPER INSTALLATION OF THIS MACHINE. **THE DEALER IS ALSO RESPONSIBLE FOR THE PROPER INITIAL TRAINING OF YOUR OPERATORS AND MAINTENANCE PERSONNEL.**

ACCEPTANCE OF SHIPMENT

Your **DRI-EAZ Big Gulp 3500®** unit was thoroughly tested, checked and inspected in its entirety prior to leaving our manufacturing facility.

When receiving your unit, please make the following acceptance check:

1. The unit should not show any signs of damage. If there is damage, notify the common carrier immediately.
2. Carefully check your equipment and packing list. The standard **DRI-EAZ Big Gulp 3500®** unit should arrive with the following items as well as any optional accessories:

EQUIPMENT LISTING

- A. **DRI-EAZ Big Gulp 3500®** console.
- B. Operation and Service manual
- C. Installation mounting plates and bolt down kit
- D. Hose clamps for vacuum and fuel hoses
- E. Waste tank with shutoff switch
- F. Waste tank filter and stainless steel strainer basket.
- G. 50 ft. 2-1/2 in. vacuum hose
- H. 50 ft. 2 in. vacuum hose
- I. 1 Vacuum hose reducer.

OPTIONAL EQUIPMENT

- Additional 50 ft.2 in. vacuum hose
 - Part # 18-003
- Additional 50 ft. 2-1/2 in. vacuum hose
 - Part # 18-333
- Additional vacuum hose connectors
 - Part # 21-003
- Rover HVE

FUEL HOOK-UP KITS BY VEHICLE

- Chevy 1997 to 2002 FI..... 69-003FI
- Chevy 2003 FI..... 69-018FI
- Chevy 2004+ Hook-Up Kit...69-033
- Chevy Box Truck 2004+..... 69-081
- Dodge 1997 to 2002 FI..... 69-004FI
- Ford FI..... 69-005FI
- Ford 2004 – 2010..... 69-061
- Ford 2011+.....69-331
- Ford Box Truck 2004+..... 68-077
- Ford Transit Connect 69-261S
- Nissan NV.....69-376

SECTION 2: **INSTALLATION**

3. INSTALLATION

| | |
|---|----|
| Lifting the unit into the vehicle..... | 9 |
| Positioning the unit into the vehicle..... | 9 |
| Fastening down the unit..... | 9 |
| Dimensional diagrams | 10 |
| Installation of fuel lines | 12 |
| Trailer fuel tank and fuel line installation..... | 12 |
| Battery Connection | 12 |
| Fire extinguisher | 13 |

3. INSTALLATION

WARNING!!!

This unit must be bolted to the floor of the vehicle by an **AUTHORIZED DISTRIBUTOR**.

LIFTING THE UNIT INTO THE VEHICLE

The **BIG GULP 3500®** console weighs approximately 635 lbs., a forklift is necessary to place the unit into the vehicle. Make **CERTAIN** that the forks are spread to the maximum width of the unit. Use C clamps to secure the unit to the forks.

POSITIONING THE UNIT INTO THE VEHICLE

Vehicles vary in size and openings. Owners have different preferences on where in the vehicle they want their units positioned. **DRI-EAZ** strongly recommends a side door installation for the **BIG GULP 3500®**. We **DO NOT** recommend a rear door installation.

1. Ensure that enough space is provided to assure adequate engine ventilation as well as room for service and maintenance.
2. The complete unit and accessories **MUST NOT** exceed the vehicle's axle weight limit.
3. **NEVER** position the console closer than 12 inches from the bottom rear of the driver and passenger seats.

FASTENING DOWN THE UNIT AND WASTE TANK

CAUTION!!!

Prior to drilling any holes in the vehicle floor, ensure that while drilling, you will not damage the fuel tank, fuel lines, or any other vital components, which could affect the safety and or operation of the vehicle.

- A. The waste tank mounting holes will serve as a template. Drill ten (10) 13/32 in. diameter holes for the waste tank.
- B. Using the provided mounting hardware kit:
 1. Insert six (6) 3/8-16 × 4 in. hex head cap screws with flat washers through the **BIG GULP®** console mounting holes, and four (4) 3/8-16 × 4 in. hex head cap screws with flat washers through the waste tank mounting holes.
 2. Install the provided mounting plates underneath the vehicle floor.
 3. Screw the provided 3/8-16 hex head lock nuts on to the mounting bolts and tighten until the console and waste tank are firmly attached to the vehicle floor.

SECTION 2

DIMENSIONAL DIAGRAM

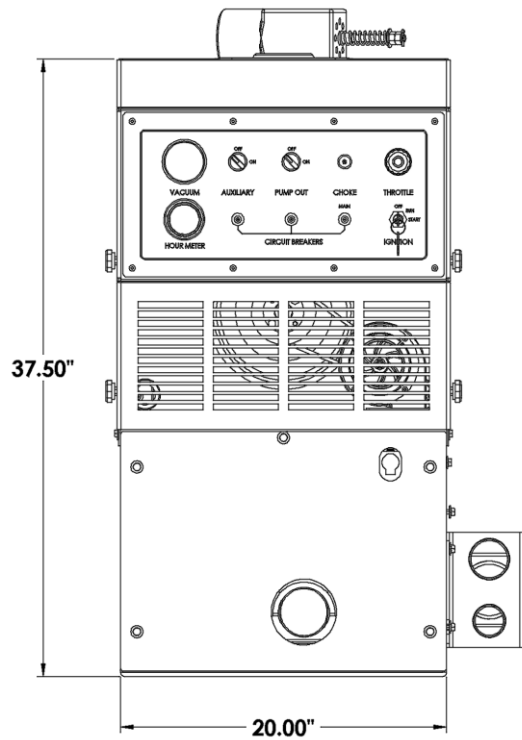
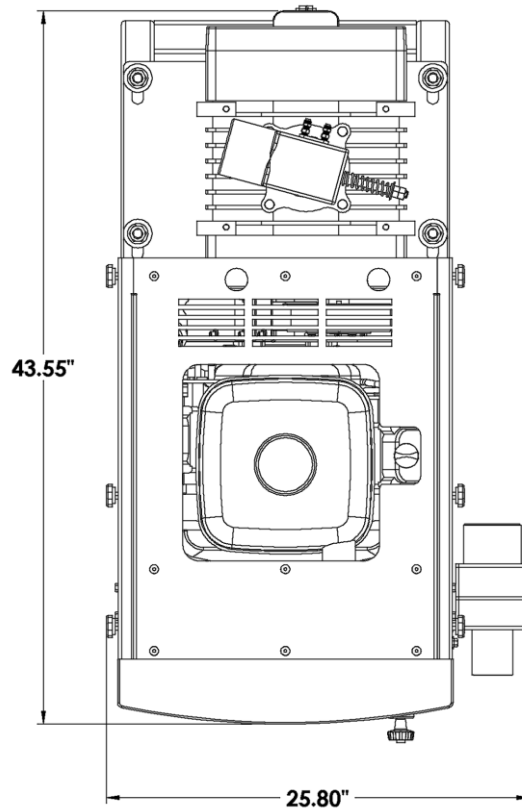

SECTION 2

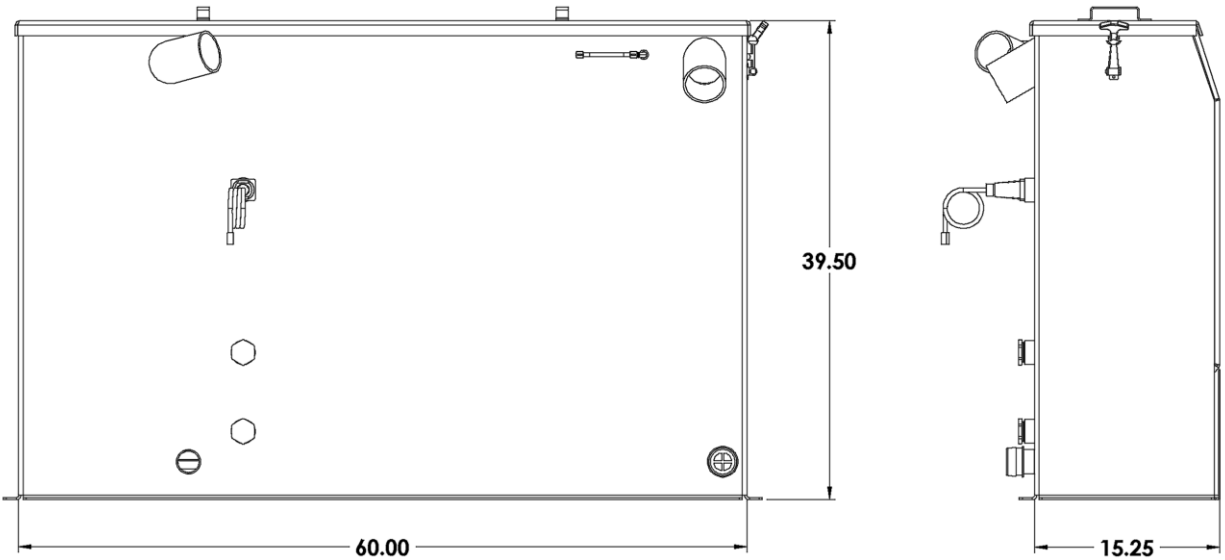

69-298 ASSY, LARGE RECOVERY TANK

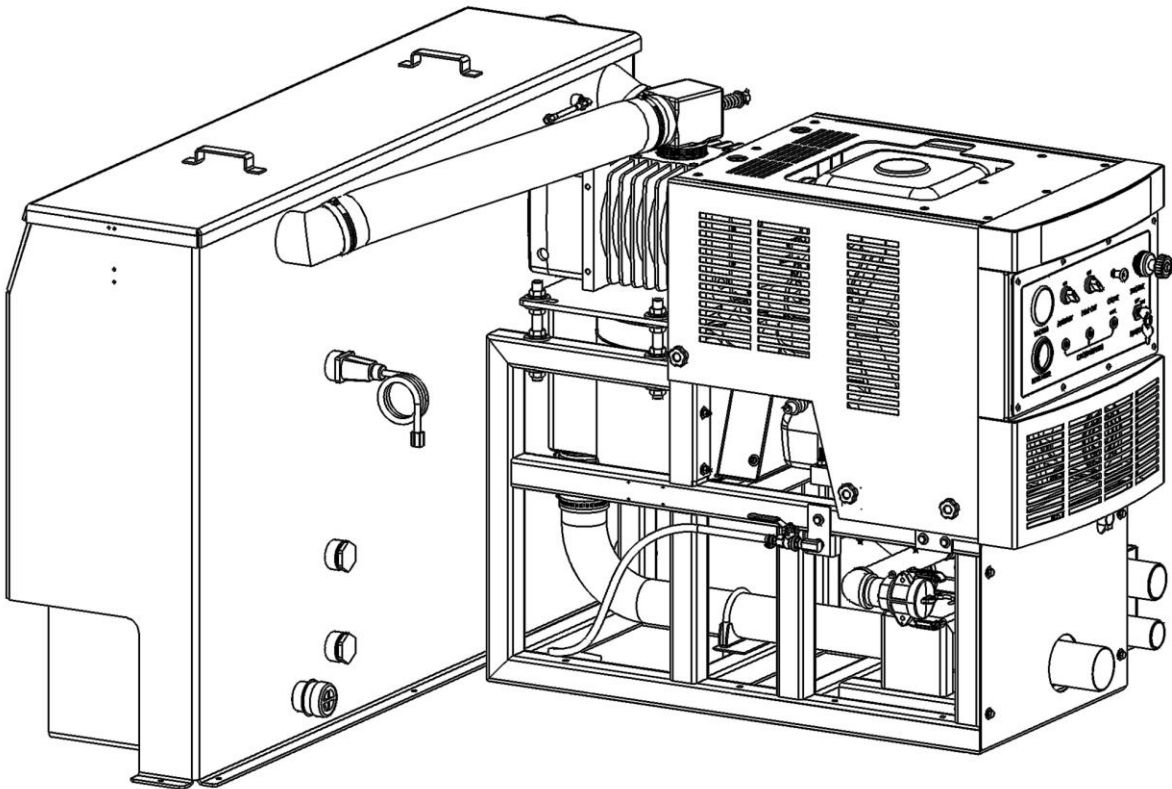

BIG GULP 3500 WITH OPTIONAL PUMP OUT INSTALLED

SECTION 2

INSTALLATION OF FUEL LINES

CAUTION!!!

READ THESE INSTRUCTIONS IN THEIR ENTIRETY PRIOR TO PROCEEDING.

WARNING!

The Vehicle fuel lines should NOT be spliced under ANY circumstances. Severe injury or fatality could result.

DO NOT damage the vehicle in any way during the installation. When routing fuel lines, **DO NOT** configure the hoses in any location where the hoses or vehicle could be damaged. Avoid contact with moving parts, areas of high temperature, brake lines, fuel lines, catalytic converters, exhaust pipes, mufflers or sharp objects. Excess heat from exhaust or other heat sources may cause the fuel pump to work improperly.

TRAILER FUEL TANK AND FUEL LINE INSTALLATION

The following are recommendations for trailer installations:

- A. Strict compliance with all federal and state laws must be maintained.
- B. Use only fuel tanks that are manufactured specifically for gasoline, have proper vented filling caps, and outlet connections that are the same size as the inlet and return connections on the unit.
- C. **DO NOT** install fuel tanks inside any type of enclosed trailer or vehicle.

WARNING!

NEVER carry gasoline or flammable materials in an enclosed trailer or vehicle.

NEVER store any type of flammable material in an enclosed trailer or vehicle.

D. Always mount fuel tanks where they will be protected from any vehicle collision.

E. When installing fuel lines from the fuel tank to the unit, use the proper size fuel line.

BATTERY CONNECTION

WARNING!

Explosive gases, Dangerous gases! Batteries contain sulfuric acid. To prevent acid burns, avoid contact with skin, eyes and clothing. Batteries also produce explosive hydrogen gases while charging. To prevent fire or explosion, charge batteries only in a well ventilated area. Keep sparks, open flames, as well as any other sources of ignition away from batteries at all times. Remove all jewelry prior to servicing batteries. Keep batteries out of the reach of children.

Before disconnecting the negative (-) ground cable, ensure that all switches are in the OFF position. If ON, a spark could occur at the ground connection terminal, which could cause an explosion if hydrogen gas or gasoline vapors are present. ALWAYS disconnect the negative (-) terminal first.

A. Attach the red positive (+) battery cable from the starter solenoid on the console to the positive (+) terminal on the battery and tighten down the nut.

B. Attach the black negative (-) battery cable from the ground on the console to the negative (-) terminal on the battery and tighten down the nut.

FIRE EXTINGUISHER

DRI-EAZ, and many government agencies, recommend that a fire extinguisher rated for A, B, and C type fires be installed into any commercial vehicle.

SECTION 3: **OPERATION**

4. SYSTEMS

| | |
|--------------------|----|
| Vacuum system..... | 15 |
|--------------------|----|

5. OPERATION

| | |
|---------------------------------------|----|
| Preparation..... | 16 |
| Starting the unit..... | 17 |
| Automatic waste pump | 17 |
| Extraction process..... | 17 |
| Shut down and daily maintenance | 18 |

4. SYSTEMS

NOTE: Read and understand this section of the manual entirely before proceeding.

Prior to proceeding into the operations and maintenance sections of this manual it is recommended that you acquire a basic understanding of how the unit functions.

VACUUM SYSTEM

The vacuum flow is initiated by the vacuum pump, or blower. An air and water mixture is drawn into the vacuum inlet on the front of the console. The

mixture flows through a strainer basket (if equipped) in the waste tank. The air exits the waste tank through a 100 mesh filtration system, into the vacuum pump. A vacuum pump relief valve is installed for vacuum pump protection.

The air is discharged from the vacuum pump through a spiral silencer.

A high level shut off sensor is located on the front of the waste tank and will shut down the unit before the tank is at full capacity. This protects the vacuum pump from water damage. **Note:** Waste tank high level shut off will not shut the unit off due to high levels of foam.

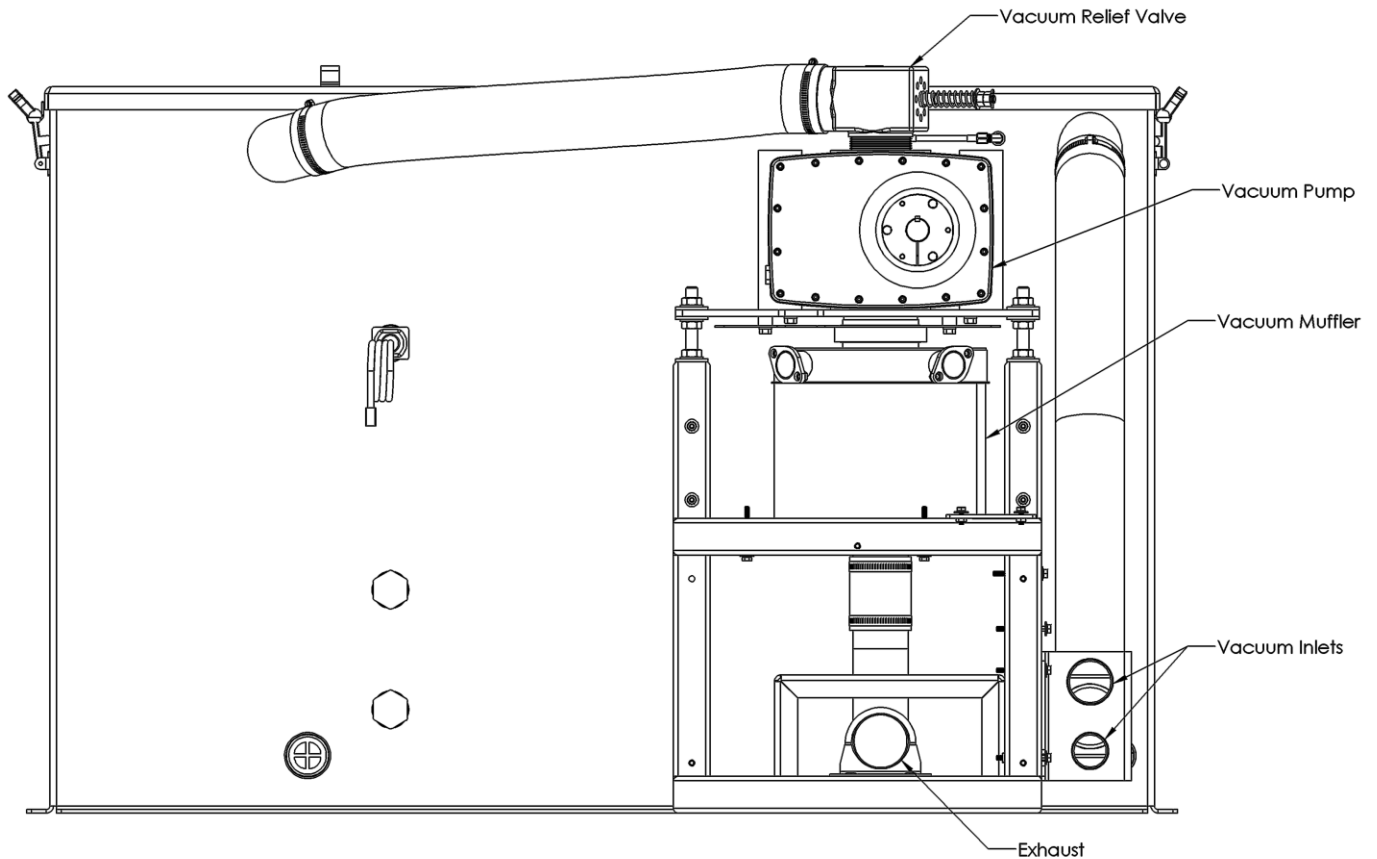

5. OPERATION

! WARNING!

PREPARATION

This section of the operator's manual explains how to prepare, start, operate, shut down and maintain your **DRI-EAZ Big Gulp 3500®** extraction unit. The **DRI-EAZ Big Gulp 3500®** extraction unit is easy to operate. However, only trained operators should proceed.

Operate this unit and equipment only in a well ventilated area. Exhaust fumes contain carbon monoxide, which is an odorless and deadly poison that can cause severe injury or death. DO NOT run this unit in an enclosed area. DO NOT operate this unit where the exhaust may enter a building doorway, window, vent or any other opening.

! ATTENTION- PRESSURE GAUGE ACCURACY

After shipment, pointer may not rest at zero due to internal case pressure buildup caused by temperature variations. Accuracy may be significantly reduced. To restore gauge to operating condition, move lever of fill plug to the "open" position. If gauge is not mounted upright, move lever to the "closed" position after venting. Repeat procedure at regular intervals to maintain gauge accuracy.

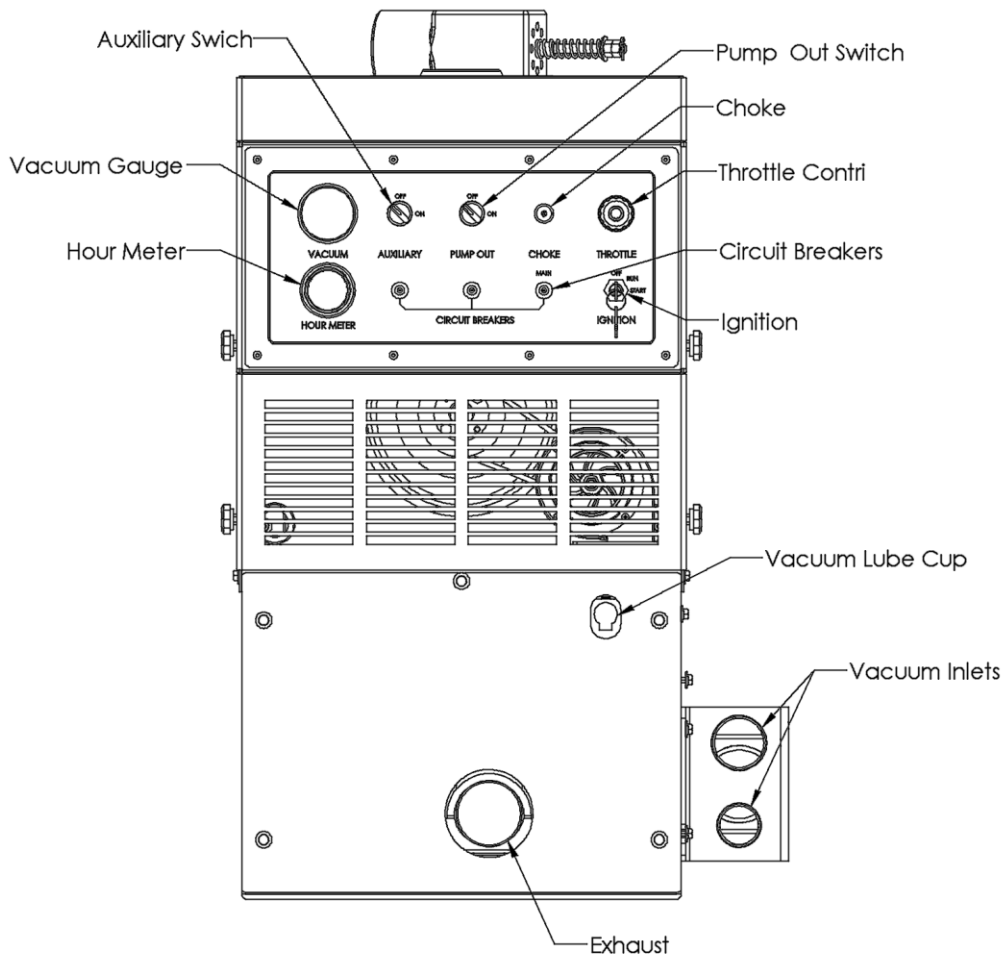

ENSURE THERE IS ADEQUATE FUEL

Check the fuel tank to ensure there is adequate fuel to complete the job and transport the vehicle. This unit consumes approximately 1.5 US gallons of fuel per hour, when unit is run under full load.

REMOVE TOOLS FROM THE VEHICLE

Remove any tools, accessories or hoses from the vehicle that you will require.

STARTING THE UNIT

1. Set throttle control in, pull out engine choke. Turn the ignition switch to the right intermediate position. Hold the switch in this position for approximately 3 seconds, allowing the fuel pump to pump fuel. Turn ignition key to start.
2. Push in engine choke after engine has started.
3. Set throttle control to desired speed.

Note: Do not operate the unit with throttle control set below 50% of maximum throttle setting.

VACUUM HOSE

Connect the vacuum hose to the vacuum inlet connection at the front of the console. Connect the opposite end of the vacuum hose to the extraction tool.

AUTOMATIC WASTE PUMP

1. Turn the auxiliary power switch on. The waste pump will now operate automatically throughout the extraction process.

⚠ WARNING!

NEVER dispose of waste water in a storm drain, water way or on ground areas. Always dispose of waste in accordance with Local, State and Federal laws.

EXTRACTION PROCESS

After you have completed the previous steps, proceed with the extraction process. Place the throttle control lever to the desired speed for extraction. A float shut-off switch is located inside of the waste tank. It will automatically shut down the unit if the tank reaches its full capacity. If this occurs, empty the waste tank before continuing.

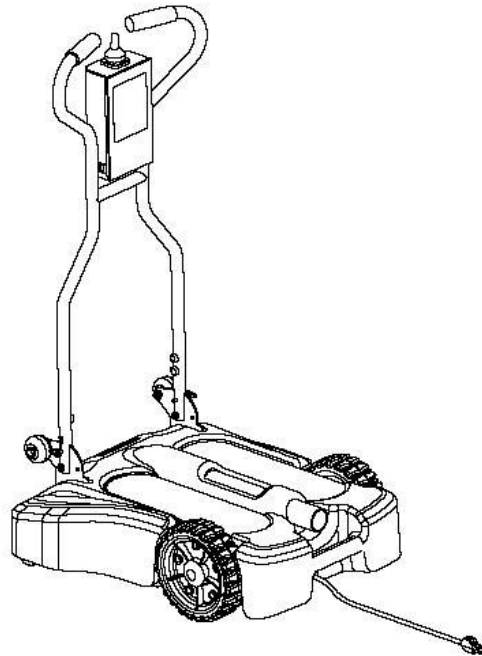

Use the **Big Gulp** with the **Rover HVE** high volume extractor for maximum water extraction from flooded carpet and pad. The Rover's unsurpassed maneuverability and special features make extraction more efficient than ever. The Rover's joystick precisely controls separate drive wheels to allow easy maneuvering around the sharpest corners. Its patent-pending stainless head with custom polymer glide has a self-healing edge that

SECTION 3

easily rides over the carpet to maximize extraction on ALL types of carpet. The unit folds flat for easy transport and storage.

SHUT DOWN AND DAILY MAINTENANCE

1. Remove as much moisture from the vacuum hoses as possible. This will prevent spillage of wastewater in your vehicle when returning hoses.

2. Disconnect the vacuum hose from the front of the console.

3. Push the throttle control lever to the slow position.

4. Allow the unit to run for at least **2 minutes**. This will help remove any moisture from the vacuum pump.

NOTE: If shutting down for the day: Plug the vacuum inlets, and set the throttle control to 50% of maximum throttle. Spray WD-40 (or equivalent) into the **blower lubrication cup**, located on the front of the console for **5 seconds**. Continue to run the unit for 1 to 2 minutes. This will lubricate the vacuum pump. Unplug the vacuum inlets, and return the throttle control lever to the slow position, and continue.

5. Turn the ignition switch to the **OFF** position.

6. Drain the waste tank, disposing of wastewater in a suitable and proper location.

WARNING!

NEVER dispose of wastewater in a storm drain, water way or on ground areas. Always dispose of waste in accordance with Local, State, and Federal laws.

7. Remove the strainer basket (if equipped) from the waste tank. Clean out any debris and re-install.

NOTE: Damage may occur to the vacuum pump. Replacement and maintenance of the filters will prevent rust and corrosion from entering the vacuum pump.

8. Inspect the vacuum inlet filters inside the waste tank **daily**. Remove and clean the filters if there is any lint or debris present.

NOTE: To remove the vacuum inlet filter, grip the plastic hexagon section of the filter. Gripping the filter by the screen will collapse or destroy the filter. After cleaning, grease the threads on the filter and replace the filter. Tighten the filter until hand tight and then loosen ¼ turn. This will make the filter easier to remove when cleaning or replacement is required.

NEVER operate this unit with the filter removed, damaged or improperly installed.

9. At the end of the work day, rinse out the waste tank with fresh water. Microban QGC cleaner is the best product for cleaning and sanitizing the waste tank as well as other parts of the system to prevent bacterial growth.

10. Clean the vehicle interior, unit, tools, hoses etc., as needed. Inspect **ALL** equipment and accessories for any damage, leaks, wear, etc.

CAUTION!

11. **Completely drain the waste tank and leave gate valve open.**

SECTION 4: **SERVICE & MAINTENANCE**

6. MAINTENANCE

| | |
|------------------------|----|
| Maintenance Chart..... | 20 |
| Engine | 21 |
| Vacuum Pump | 22 |

7. GENERAL SERVICE ADJUSTMENTS

| | |
|---------------------------|----|
| Engine | 23 |
| Vacuum Relief Valve | 23 |

8. TROUBLESHOOTING

| | |
|---------------------------|----|
| Blower / Vacuum Pump..... | 24 |
| Engine | 24 |

MAINTENANCE CHART

| | | |
|-------------------------------|------------|---|
| Engine | Daily | Check engine oil level.** Fill to proper level. DO NOT OVERFILL |
| Vacuum Pump | Daily | Spray WD-40 (or Equivalent) into the lubrication cup for 5 seconds. |
| Vacuum Inlet Filter | Daily* | Inspect filter, clean daily, and or replace if required. |
| Strainer Basket (if equipped) | Daily | Empty and clean stainless steel basket. |
| Vacuum Hoses | Daily | Rinse with fresh water. |
| Waste Pump-Out | Daily* | Inspect and remove any debris or sediment. |
| Rinse Tank & Clean | Daily | Rinse tank and clean. |
| Vacuum Pump | Daily* | Check vacuum pump oil level. Fill to proper level. DO NOT OVERFILL. |
| Engine | Monthly | Check air cleaner for damaged, dirty, or loose parts. |
| Engine | Monthly | Inspect air intake and cooling areas. Clean if required. |
| Battery | Monthly* | Check fluid level. Fill with distilled water only. DO NOT OVERFILL. |
| Engine | 50 Hours | Change engine oil and filter.** |
| Battery | 100 Hours | Clean battery terminals. |
| Engine | 200 Hours | Check spark plugs and clean if necessary. |
| Engine | 200 Hours | Clean engine air filter. |
| Engine | 250 Hours | Adjust Valve Clearances |
| Engine | 500 Hours | Replace in-line fuel filter.**** |
| Pulleys and Hubs | 500 Hours | Check pulley and hub set screws for proper torque.*** |
| Engine | 1000 Hours | Replace spark plugs. |
| Engine | 1000 Hours | Replace air filter element. |
| Vacuum Pump | 2000 Hours | Drain, flush, and replace oil.***** |

To maximize the operating life and performance, use only recommended oils, filters and greases.

*Or as often as required.

Change engine oil and oil filter after **first 5 to 8 hours of operation.

***Check pulley and hub set screws after **first 50 hours** of operation, and again at **100 hours** of operation.

****Or every **6 Months**. Whichever comes first.

*****Or **Yearly**. Whichever comes first.

6. MAINTENANCE

This section of the operator's manual contains the service and maintenance information for the **DRI-EAZ Big Gulp 3500®**. A planned preventative maintenance program will ensure that your **DRI-EAZ Big Gulp 3500®** has optimum performance, long operating life, and a minimum amount of down time.

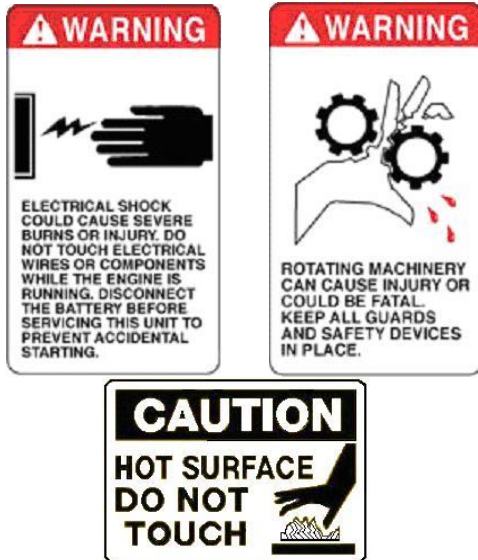

WARNING!

DO NOT attempt to service this unit while it is running. High speed parts as well as high temperature components may result in severe injury, severed limbs, or fatality.

ENGINE

1. Check the engine oil level daily. Ensure that the proper oil level is maintained. **NEVER** overfill.
2. Change the oil after the first **5 to 8 hours** of operation. Thereafter, change oil and oil filter every **50 to 100 hours** of operation.
USE ONLY BRIGGS & STRATTON BRAND OIL FILTERS. USE OF ANY OTHER TYPE OF OIL FILTER WILL VOID ENGINE WARRANTY.

Use SAE 30 high-quality oil 10W-30 synthetic oil that meets current API (American Petroleum Institute) service classifications. **Do not use additives.**

NOTE: Using a lower service class oil or extending oil change intervals longer than recommended can cause engine damage.

NOTE: Synthetic oils meeting the listed classifications may be used with oil changes performed at recommended intervals. However to allow piston rings to properly seat, a new or rebuilt engine should be operated for at least **50 hours** using standard petroleum based oil before switching to synthetic oil.

3. Check the spark plugs every **200 hours**. Replace spark plugs every **1000 hours**.
4. Clean the engine air filter element every **200 hours**. Replace the element every **1000 hours or yearly**.
5. Replace the in-line fuel filter **yearly**.
6. Adjust intake and exhaust valve clearances every **250 hours**.

| | |
|-------------------------|-----------------------------------|
| Intake Valve Clearance | 0.004 - 0.006 in (0.10 - 0.15 mm) |
| Exhaust Valve Clearance | 0.004 - 0.006 in (0.10 - 0.15 mm) |

NOTE: Additional engine service information can be obtained from the provided Briggs & Stratton Operation and Maintenance manual. If service or repair is required, contact an authorized Briggs & Stratton Service Center. They will require the serial number of the engine.

SECTION 4

VACUUM PUMP

NOTE: Refer to the provided Vacuum Pump Operation and Service Manual for specific instructions.

Lubrication: DRI-EAZ recommends that you use only AEON PD-XD Synthetic Blower Lubricant on both ends of the vacuum pump for all operating temperatures. AEON PD-XD is formulated specifically for positive displacement blower service to provide maximum blower protection at any temperature. One filling of AEON PD-XD will last a minimum of twice as long as a premium mineral oil.

NOTE: AEON PD-XD (Part # 13-004) is the only oil that DRI-EAZ puts in the vacuum pump at the factory. Adding petroleum oil to synthetic oil is **NOT** recommended.

1. Check the oil level **daily** to ensure the proper level. Too little oil will damage and ruin the bearings and gears. Too much oil will result in overheating.

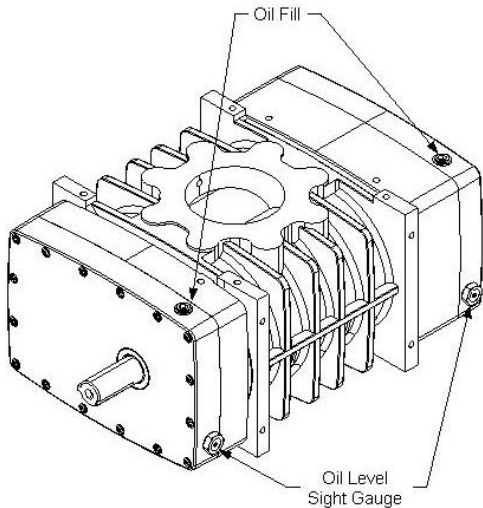

2. A lubrication cup has been provided at the front of the console, to prevent rust from building up inside of the vacuum pump. Run the unit for at least **2 minutes** to remove any moisture from the vacuum pump. Then, spray WD-40 (or Equivalent) into the lubrication cup for **5 seconds** while the

unit is running and the vacuum inlet ports are sealed. This procedure should be done at the end of **every working day**.

3. Drain, flush and replace the oil every **2000 hours or yearly, whichever comes first**.

7. GENERAL SERVICE **ADJUSTMENTS**

WARNING!

DO NOT attempt to service this unit while it is running. High speed parts as well as high temperature components may result in severe injury, severed limbs, or fatality.

ENGINE SPEED

1. To adjust the engine RPM, refer to the Briggs & Stratton Engine Operation and Service Manual for specific instructions.

WARNING!

DO NOT attempt to adjust without a tachometer and NEVER adjust the engine above 3000 RPM.

VACUUM RELIEF VALVE

With the unit running at full RPM, block off the airflow at the vacuum inlet ports and read the vacuum gauge. If adjustment is required, shut the unit down and adjust the locking nut tension on the vacuum relief valve. Re-start the unit and read the vacuum gauge. Repeat this process until the vacuum relief valve opens at 14" Hg.

TROUBLE SHOOTING

VACUUM PUMP

| PROBLEM | CAUSE | SOLUTION |
|---|---|--|
| Loss of vacuum : While cleaning, the vacuum is not up to specification.. | Improper throttle adjustment. | Adjust throttle to set desired vacuum pressure. |
| | Vacuum gauge is giving an improper reading. | Examine the tubing between the vacuum relief valve and the vacuum gauge and remove any blockage. |
| | Vacuum hose(s) is damaged, causing a suction leak. | Inspect hose(s), repair or replace. |
| | Waste tank gaskets not sealing properly, not positioned properly | Inspect the gasket. Repair seal or replace Re-position lid(s). |
| | Plugged vacuum hose or vacuum plumbing between vacuum inlet and waste tank. | Unplug vacuum hose or inlet plumbing. |
| | Waste tank filter or strainer basket (if equipped) is plugged. | Clean or replace filter. Clean strainer basket. |
| | Waste tank drain valve is damaged or left open, causing a vacuum leak. | Drain the waste tank. Close drain valve, if open. Remove the dump valve and, after inspecting, replace the defective components. |
| | Vacuum relief valve diaphragm is damaged. | Re-adjust the vacuum relief valve. If the vacuum does not increase, remove and inspect the relief valve diaphragm. If damaged replace. |
| Vacuum pump is worn out. | Replace the vacuum pump. | |
| Excessive Vacuum: | Vacuum relief valve requires adjustment. | Readjust the vacuum relief valve. |

ENGINE

| PROBLEM | CAUSE | SOLUTION |
|--|---|---|
| Engine stops running: While doing normal extraction, the engine stops running | Engine is out of gasoline | Add gasoline to the fuel tank. |
| | Waste tank is full | Empty waste tank. |
| | Main circuit breaker on the control panel has been tripped. | After inspecting the unit to determine the cause of the tripped circuit breaker, reset button the circuit breaker. |
| | Defective fuel pump. | Replace fuel pump. |
| | Defective float switch on the waste tank. | Check switch for proper operation. Replace as necessary. |
| | Oil pressure switch on engine has shut down due to insufficient oil pressure. | Refer to the Briggs & Stratton Engine Operation and Maintenance Manual. DO NOT restart the engine until the cause is determined and corrected. |
| | No ignition in the engine or engine is malfunctioning. | Refer to the Briggs & Stratton Engine Operation and Maintenance Manual. |
| Automatic waste pump is malfunctioning or not operating normally. | Defective waste pump float switch. | Replace float switch. |
| | Broken diaphragm(s). | Replace diaphragm(s). |
| | Weak battery. | Charge or replace battery if needed. Check charging station. |
| | Pump-out circuit breaker on control panel has been tripped. | After inspecting waste pump to determine the cause of the tripped circuit breaker, press the reset button. |

SECTION 5: **SERVICE & MAINTENANCE**

9. ILLUSTRATED PARTS LISTINGS

| | |
|------------------------------------|----|
| Big Gulp Console Assembly | 26 |
| Frame Assembly | 28 |
| Control Panel Assembly | 29 |
| Engine Assembly | 30 |
| Engine Fuel System | 31 |
| Belt Guard Assembly..... | 32 |
| Vacuum Pump Assembly | 33 |
| Vacuum Break Assembly | 34 |
| Muffler and Exhaust Assembly | 35 |
| Automatic Pump-Out Kit..... | 36 |
| Pump-Out Antifreeze Kit..... | 37 |
| Waste Tank | 38 |
| Decals | 39 |
| Electrical Diagram | 40 |

10. ACCESSORIES

| | |
|--|----|
| Rover HVE | 41 |
| Stryker Wand | 41 |
| Hose Reels | 42 |
| Waste Pump Out Assembly | 44 |
| 1992 to 2002 Ford Fuel Line Install | 45 |
| Chevy and GMC Full Size Van Fuel Line Install | 46 |
| 2003 Chevy and GMC Full Size Van Fuel Line Install | 47 |
| 1997-2002 Dodge Full Size Van Fuel Line Install..... | 48 |
| Fuel Line Bulkhead Installation | 49 |
| Fuel Pump Assembly Installation..... | 50 |
| Fuel Supply & Return Line Installation..... | 51 |

SECTION 4

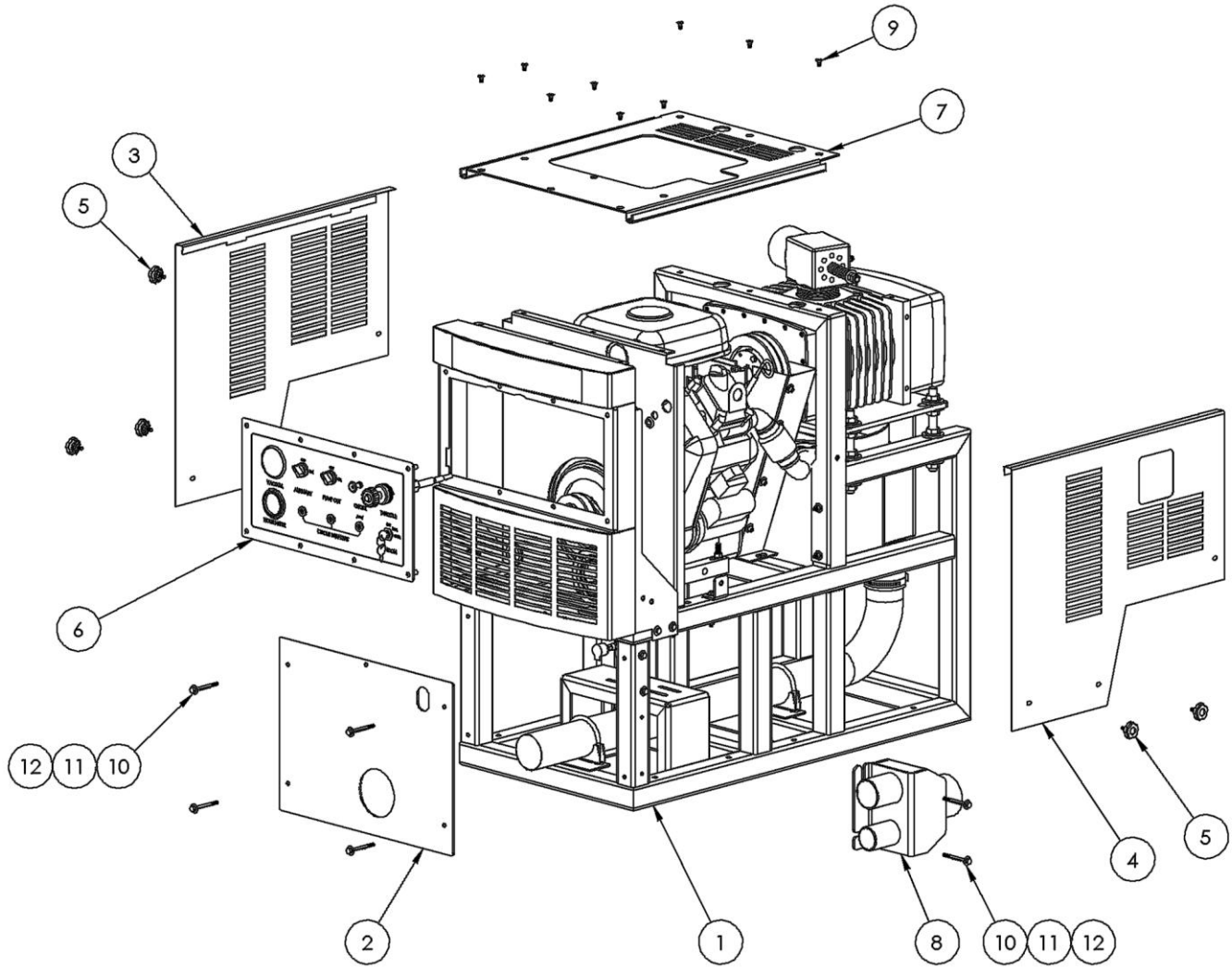

BIG GULP 3500 CONSOLE ASSEMBLY

| Item No. | Part Number | Qty | Description |
|----------|-------------|-----|-----------------------------------|
| 1 | 69-387 | 1 | ASSY, FRAME |
| 2 | 66-356 | 1 | PANEL, LOWER FRONT |
| 3 | 58-393 | 1 | PANEL, LEFT SIDE |
| 4 | 58-394 | 1 | PANEL, RIGHT SIDE |
| 5 | 11-007 | 6 | NUT, THUMB 1/4-20 FLWR HEAD KNOB |
| 6 | 69-195 | 1 | ASSY, CONTROL PANEL |
| 7 | 58-392 | 1 | PANEL, TOP |
| 8 | 61-714 | 1 | WELDMENT, DUAL VAC BRACKET |
| 9 | 10-144 | 9 | SCREW, MACH 1/4-20 X 1/2 FHSCS SS |
| 10 | 12-012 | 13 | WASHER, FLAT 1/4 USS |
| 11 | 12-015 | 13 | LKWSR, 1/4 ZINC |
| 12 | 10-028 | 9 | SCREW, MACH 1/4-20 X 2-3/4 HXHD |

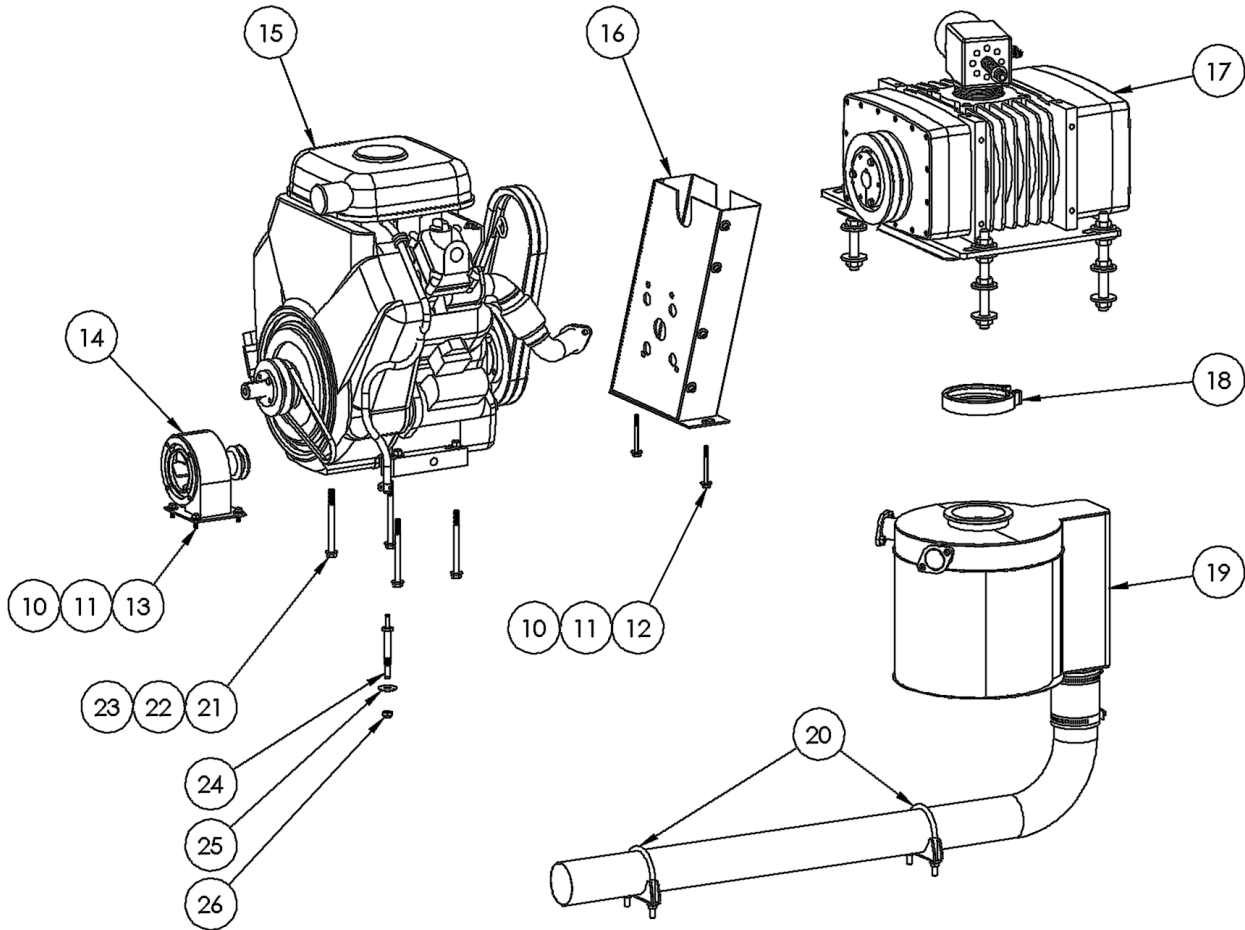

BIG GULP 3500 CONSOLE ASSEMBLY CONTINUED...

| Item No. | Part Number | Qty | Description |
|----------|-------------|-----|--|
| 10 | 12-012 | 13 | WASHER, FLAT 1/4 USS |
| 11 | 12-015 | 13 | LKWSR, 1/4 ZINC |
| 12 | 10-028 | 9 | SCREW, MACH 1/4-20 X 2-3/4 HXHD |
| 13 | 10-025 | 4 | SCREW, MACH 1/4-20 X 3/4 HXHD |
| 14 | 69-184 | 1 | ASSY, BELT GUARD BLOWER |
| 15 | 69-391 | 1 | ASSY, ENGINE |
| 16 | 69-207 | 1 | ASSY, BELT GUARD |
| 17 | 69-386 | 1 | ASSY, VACUUM BLOWER |
| 18 | 14-056 | 1 | CLAMP, V-BAND 4.75 IN DIA |
| 19 | 69-390 | 1 | ASSY, SILENCER AND EXHAUST |
| 20 | 14-002 | 2 | CLAMP, MUFFLER 3 IN |
| 21 | 10-161 | 4 | BOLT, 3/8-16 X 4-1/2 HH ZP |
| 22 | 12-013 | 8 | WASHER, FLAT 3/8 SAE |
| 23 | 11-019 | 4 | NUT, 3/8-16 NYLOK |
| 24 | 66-359 | 1 | FITTING, 1/4 X 5/16 FUEL LINE MANIFOLD |
| 25 | 12-021 | 1 | WASHER, FLAT 7/16 ZINC |
| 26 | 11-088 | 1 | NUT, 7/16-20 THIN NYLOK ZPS |

SECTION 4

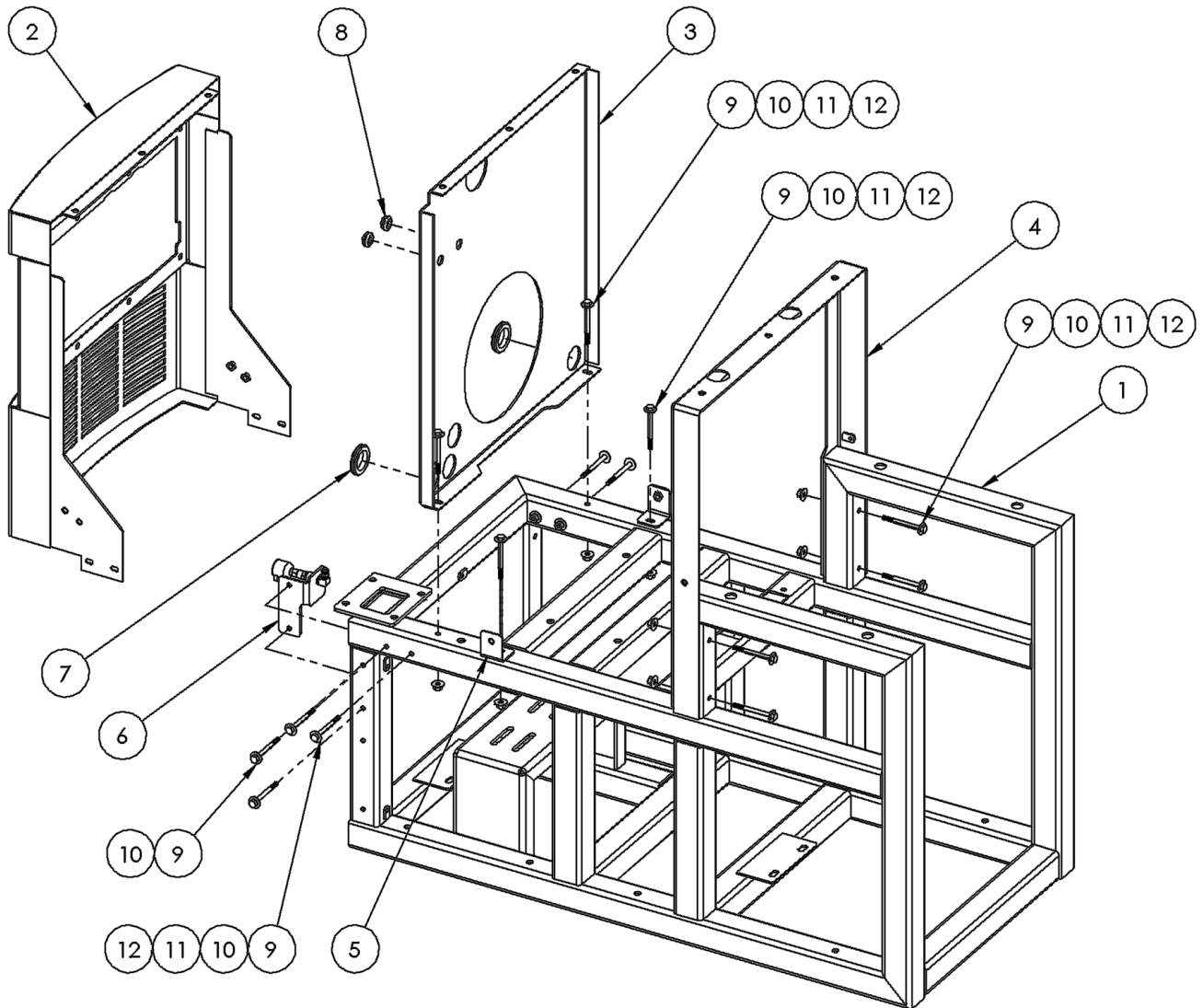

69-387, FRAME ASSEMBLY

| Item No. | Part Number | Qty | Description |
|----------|-------------|-----|--------------------------------------|
| 1 | 61-778 | 1 | WELDMENT, FRAME 3500 BIG BLOCK |
| 2 | 61-486 | 1 | WELDMENT, CONTROL PANEL |
| 3 | 60-467 | 1 | PANEL, AIR DAM |
| 4 | 60-440 | 1 | FRAME, REAR BRACE |
| 5 | 60-398 | 2 | ANGLE, HOOD MOUNTING |
| 6 | 69-389 | 1 | ASSY, OIL CUP BRACKET |
| 7 | 41-020 | 2 | GROMMET, 1-7/8 OD X 1-1/4 ID |
| 8 | 41-070 | 2 | GROMMET, 7/8 OD X 3/8 ID X 1/8 PANEL |
| 9 | 12-012 | 26 | WASHER, FLAT 1/4 USS |
| 10 | 10-028 | 14 | SCREW, MACH 1/4-20 X 2-3/4 HXHD |
| 11 | 11-004 | 12 | NUT, 1/4-20 ZINC |
| 12 | 12-015 | 14 | LKWSR, 1/4 ZINC |

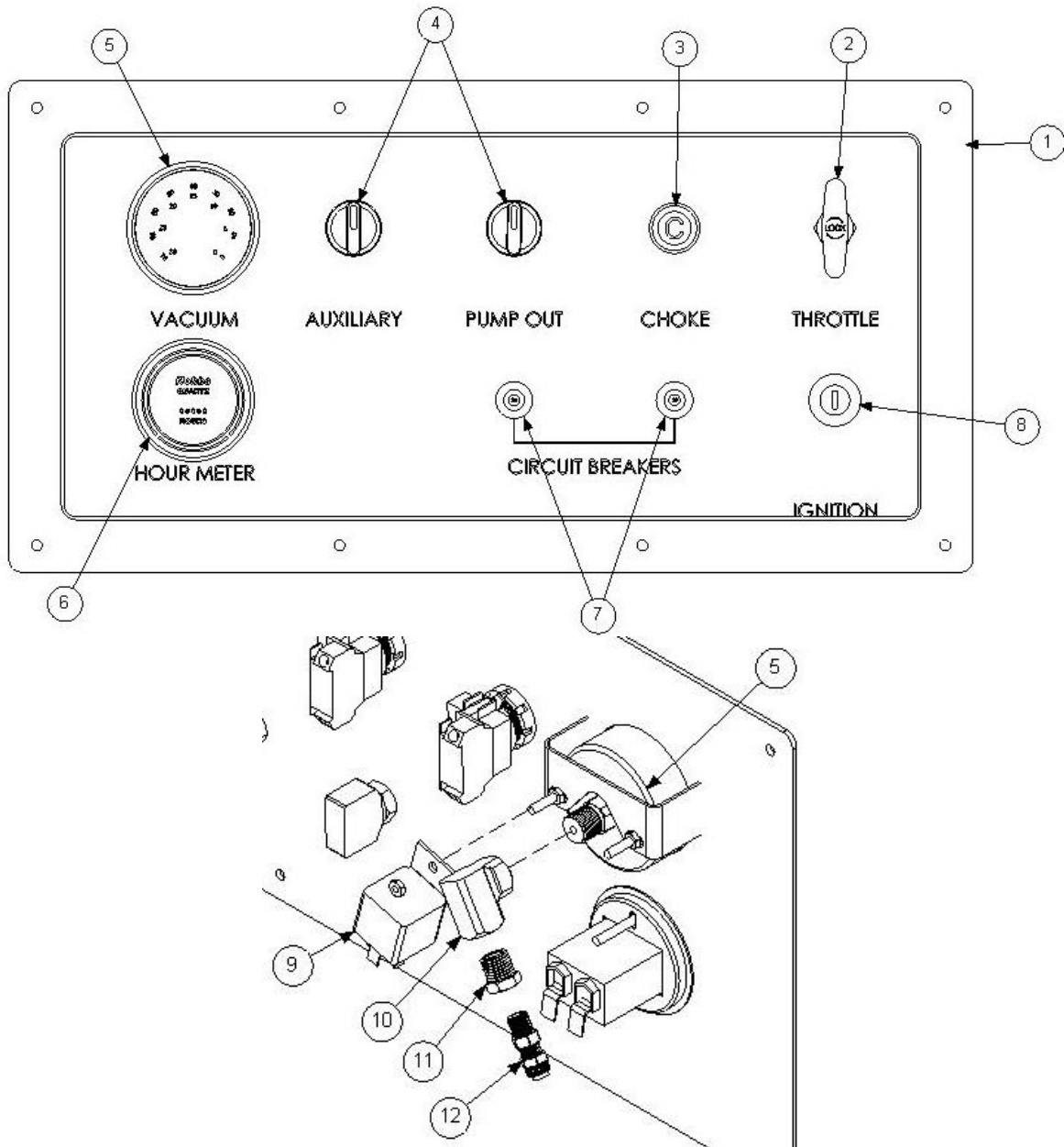

69-195 ASSY, CONTROL PANEL, BIG GULP 3500

| Item No. | Part Number | Qty | Description |
|----------|-------------|-----|-----------------------------------|
| 1 | 58-386 | 1 | PANEL, INSTRUMENT, BIG GULP |
| 2 | 40-000 | 1 | CABLE, THROTTLE |
| 3 | 40-001 | 1 | CABLE, CHOKE |
| 4 | 29-016 | 2 | SWITCH, ROTARY NON ILLUMINATED |
| 5 | 26-040 | 1 | GUAGE, VACUUM 2.5 IN 0-30 IN/HG |
| 6 | 26-010 | 1 | HOURMETER, HOBBS |
| 7 | 30-008 | 2 | BREAKER, 20 AMP |
| 8 | 36-334 | 1 | KEY SET, BRIGGS & STRATTON 392832 |
| 9 | 34-010 | 1 | RELAY, ENG.SHTDWN12V20-30AMP |
| 10 | 21-037 | 1 | FITTING, ELBOW 1/4 IN NPT, BRASS |
| 11 | 21-076 | 1 | BUSHING, 1/4 M X 1/8 F BRASS |
| 12 | 21-028 | 1 | CONN, 1/8 P X 1/4 POLY |

SECTION 4

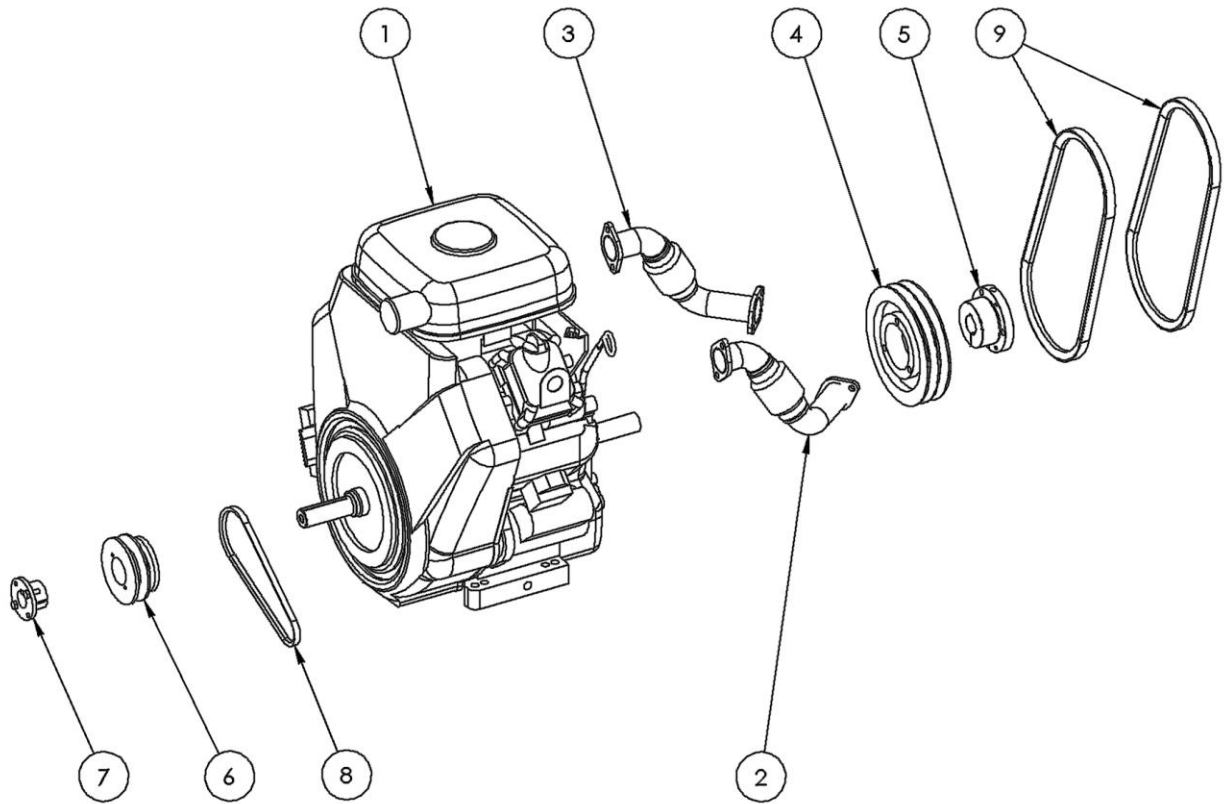

69-391, ENGINE ASSEMBLY

| Item No. | Part Number | Qty | Description |
|----------|-------------|-----|---------------------------------|
| 1 | 45-032 | 1 | ENGINE, BRIGGS & STRATTON 31 HP |
| 2 | 61-535 | 1 | WELDMENT, EXHAUST PIPE RS |
| 3 | 61-534 | 1 | WELDMENT, EXHAUST PIPE LS |
| 4 | 38-028 | 1 | PULLEY, 5V710SK 2G |
| 5 | 38-032 | 1 | HUB, SK 1.25 |
| 6 | 66-367 | 1 | PULLEY, ENGINE FRONT |
| 7 | 38-052 | 1 | BUSHING, BROWNING H X 1.125 |
| 8 | 37-072 | 1 | BELT, 3L220 GATES EPDM |
| 9 | 37-066 | 2 | BELT, GATES 5V412 EPDM |

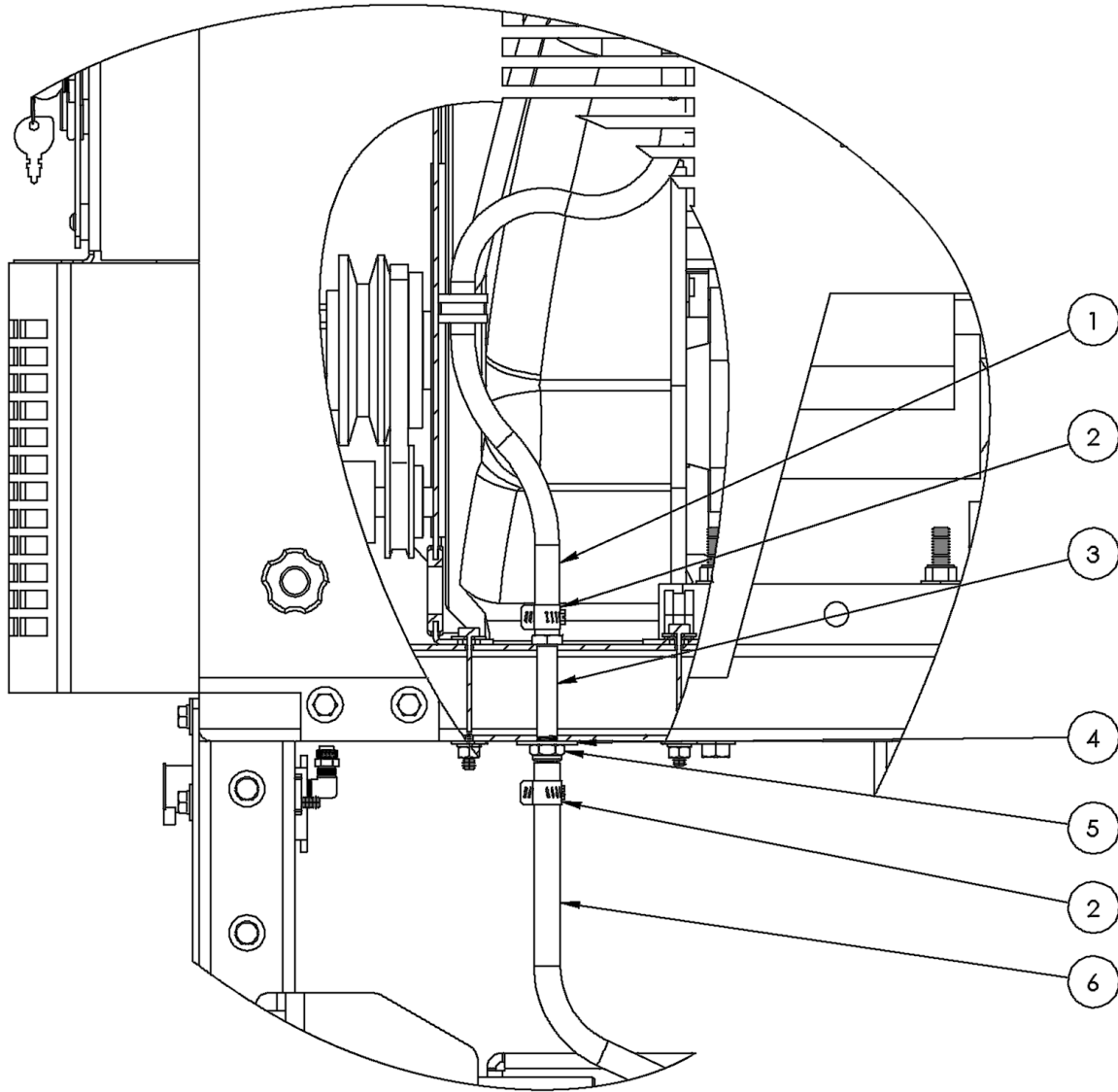

ENGINE FUEL SYSTEM

| Item No. | Part Number | Qty | Description |
|----------|-------------|---------|--|
| 1 | 16-104 | 1.83 FT | HOSE, FUEL 1/4 30R9 FUEL INJECTION |
| 2 | 14-007 | 2 | CLAMP, HOSE #4 |
| 3 | 66-359 | 1 | FITTING, 1/4 X 5/16 FUEL LINE MANIFOLD |
| 4 | 12-021 | 1 | WASHER, FLAT 7/16 ZINC |
| 5 | 11-088 | 1 | NUT, 7/16-20 THIN NYLOK ZPS |
| 6 | 16-103 | 6.00 FT | HOSE, FUEL 5/16 30R9 FUEL INJECTION |

SECTION 4

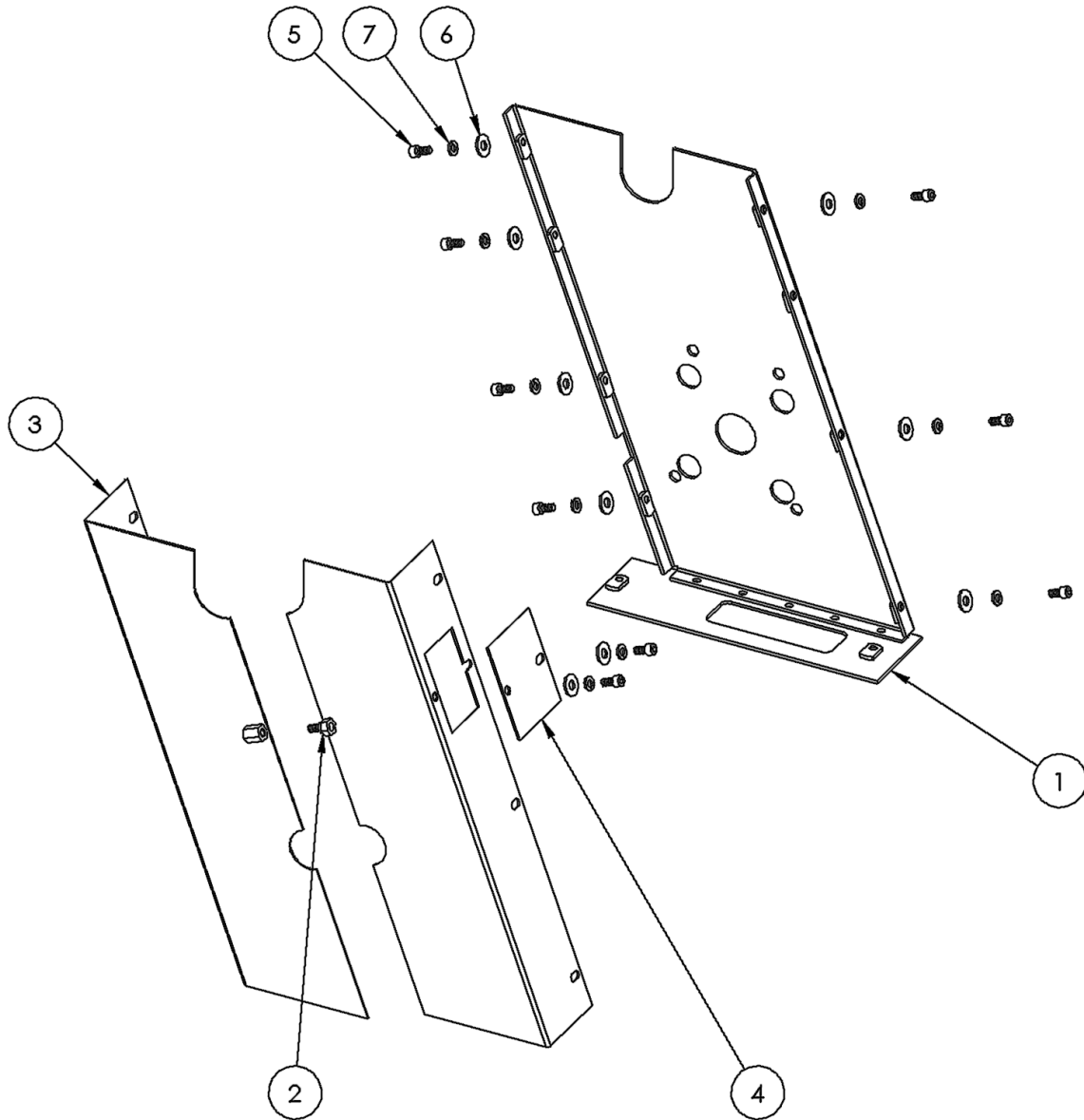

69-207 ASSEMBLY, BELT GUARD

| Item No. | Part Number | Qty | Description |
|----------|-------------|-----|------------------------------------|
| 1 | 61-509 | 1 | WELDMENT, BELT GUARD |
| 2 | 61-782 | 1 | WELDMENT, BELT GUARD LS |
| 3 | 61-783 | 1 | WELDMENT, BELT GUARD RS |
| 4 | 58-403 | 1 | PLATE, BELT GUARD INSPECTION COVER |
| 5 | 10-007 | 10 | SCREW, MACH 1/4-20 X 1/2 SOCHD SS |
| 6 | 12-012 | 9 | WASHER, FLAT 1/4 USS |
| 7 | 12-015 | 9 | LKWSR, 1/4 ZINC |

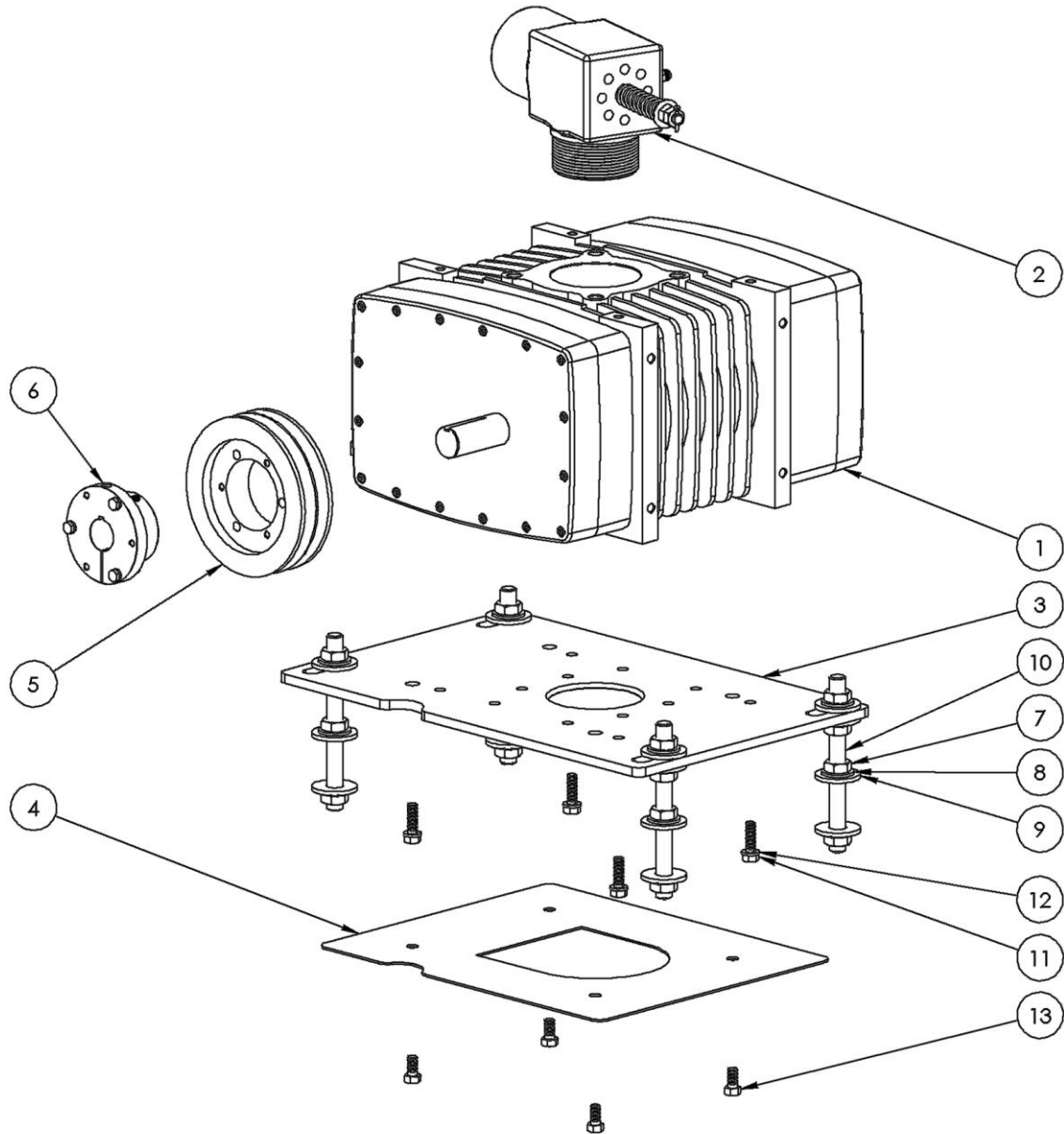

69-386 ASSEMBLY, VACUUM PUMP

| Item No. | Part Number | Qty | Description |
|----------|-------------|-----|--------------------------------------|
| 1 | 46-070 | 1 | VACUUM PUMP, TRIFLOW 408 HORIZ RH CW |
| 2 | 69-392 | 1 | ASSEMBLY, VACUUM BREAK |
| 3 | 61-564 | 1 | WELDMENT, PLT VAC PUMP MOUNT |
| 4 | 58-447 | 1 | PANEL, HEAT SHIELD |
| 5 | 38-027 | 1 | PULLEY 5V630SK |
| 6 | 38-032 | 1 | HUB SK 1.25 |
| 7 | 11-062 | 16 | NUT, 5/8-18 JAM |
| 8 | 12-039 | 16 | WASHER, LOCK 5/8 |
| 9 | 12-040 | 16 | WASHER, FLAT 5/8 |
| 10 | 66-227-04 | 4 | THREADED ROD, 5/8-18 UNF 2A X 7 IN |
| 11 | 10-004 | 4 | SCREW, MACH 3/8-16 X 1-1/4 HEXHD |
| 12 | 12-014 | 8 | LKWSR, 3/8 ZINC |
| 13 | 10-070 | 4 | BOLT, 3/8-16 X 3/4 HH ZP |

SECTION 4

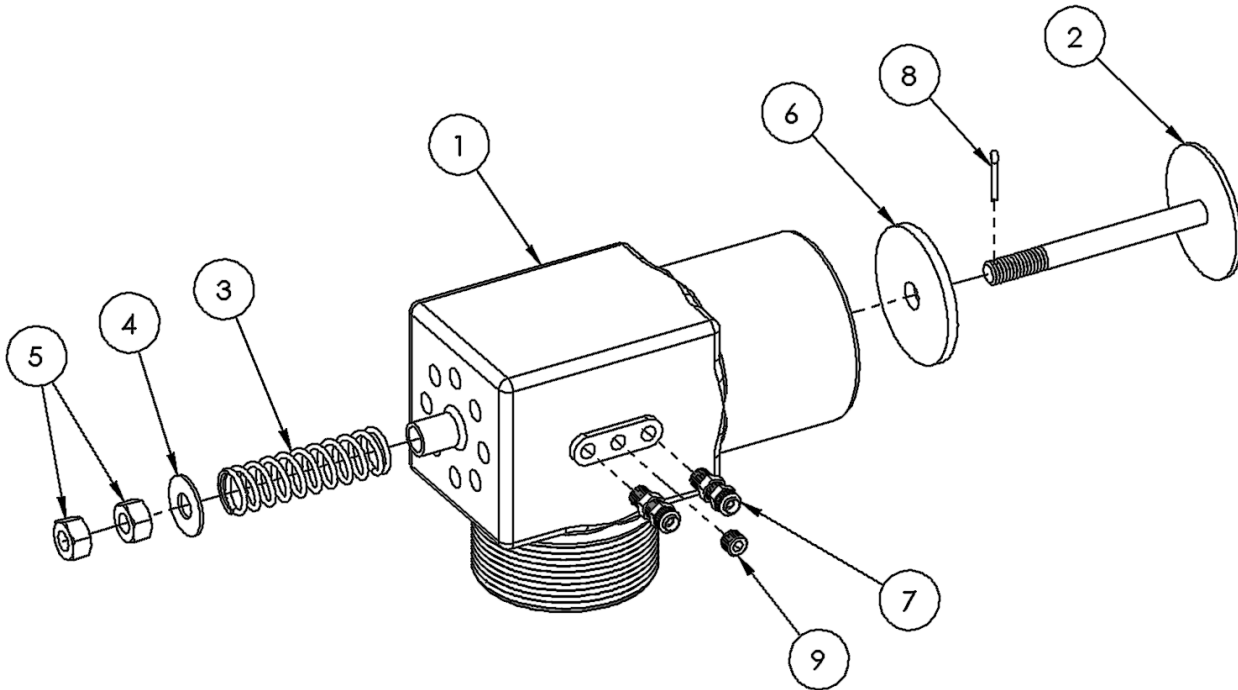

69-392 ASSY, VACUUM BREAK

| Item No. | Part Number | Qty | Description |
|----------|-------------|-----|------------------------------------|
| 1 | 66-001 | 1 | VACUUM BREAK, MACHINED 4L |
| 2 | 61-035 | 1 | STEM, VACUUM RELIEF VALVE 4L 5M |
| 3 | 15-033 | 1 | SPRING, VACUUM RELIEF VALVE |
| 4 | 12-021 | 1 | WASHER, FLAT 7/16 ZINC |
| 5 | 11-012 | 2 | NUT, 7/16-14 ZINC |
| 6 | 41-078 | 1 | DIAPHRAM, VAC RELIEF BIG GULP 3500 |
| 7 | 21-028 | 2 | CONN, 1/8 P X 1/4 POLY |
| 8 | 14-032 | 1 | PIN, COTTER .109 X .75 SS |
| 9 | 21-029 | 1 | PLUG, 1/8 NPT SOCKET HD BRASS |

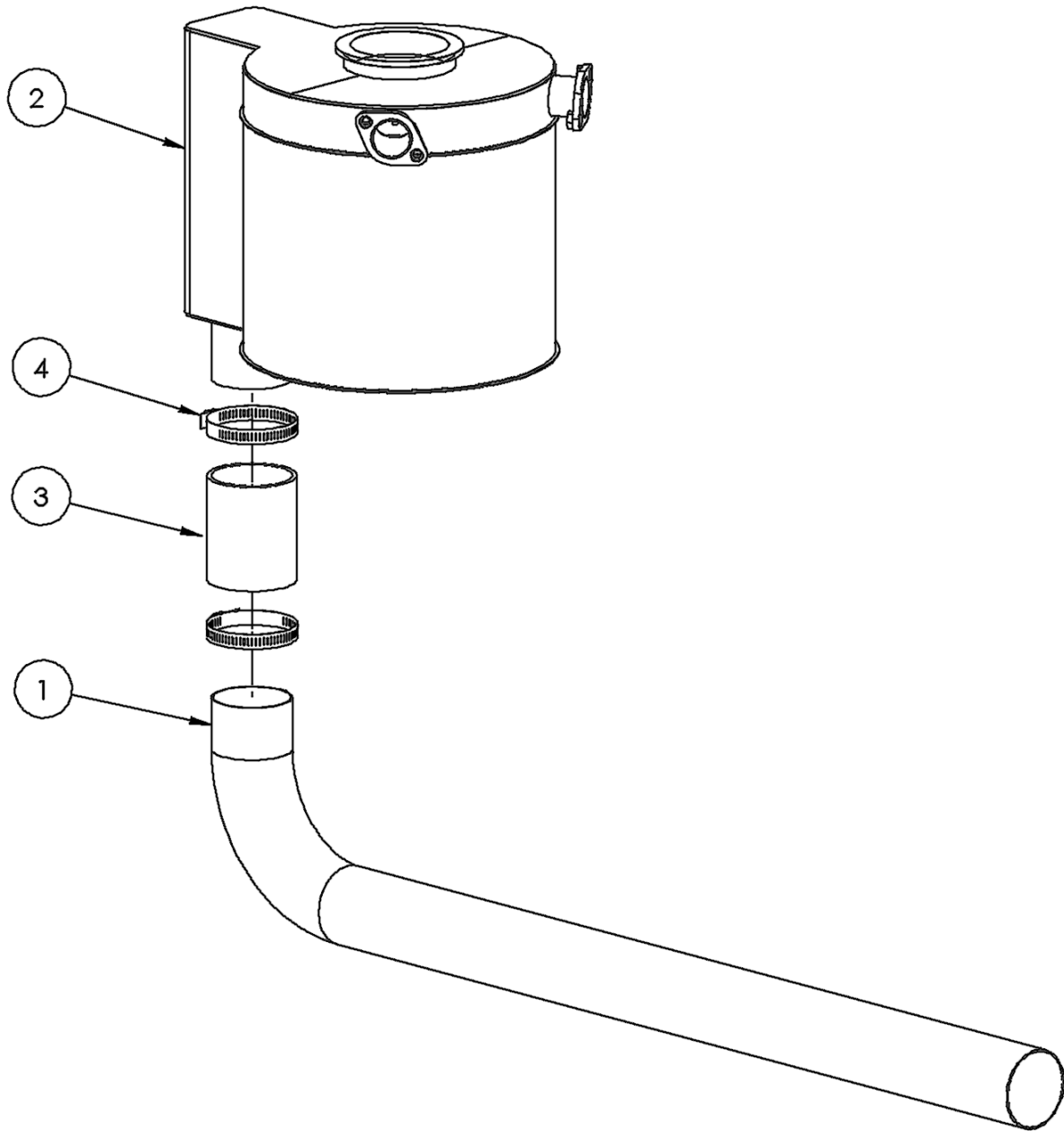

69-390 ASSY, MUFFLER AND EXHAUST

| Item No. | Part Number | Qty | Description |
|----------|-------------|-----|------------------------------|
| 1 | 61-781 | 1 | WELDMENT, EXHAUST TUBE |
| 2 | 61-779 | 1 | WELDMENT, SILENCER |
| 3 | 16-100 | 1 | HOSE, 3 IN ID X 3FT SILICONE |
| 4 | 14-024 | 2 | CLAMP, HOSE #48 SS |

SECTION 4

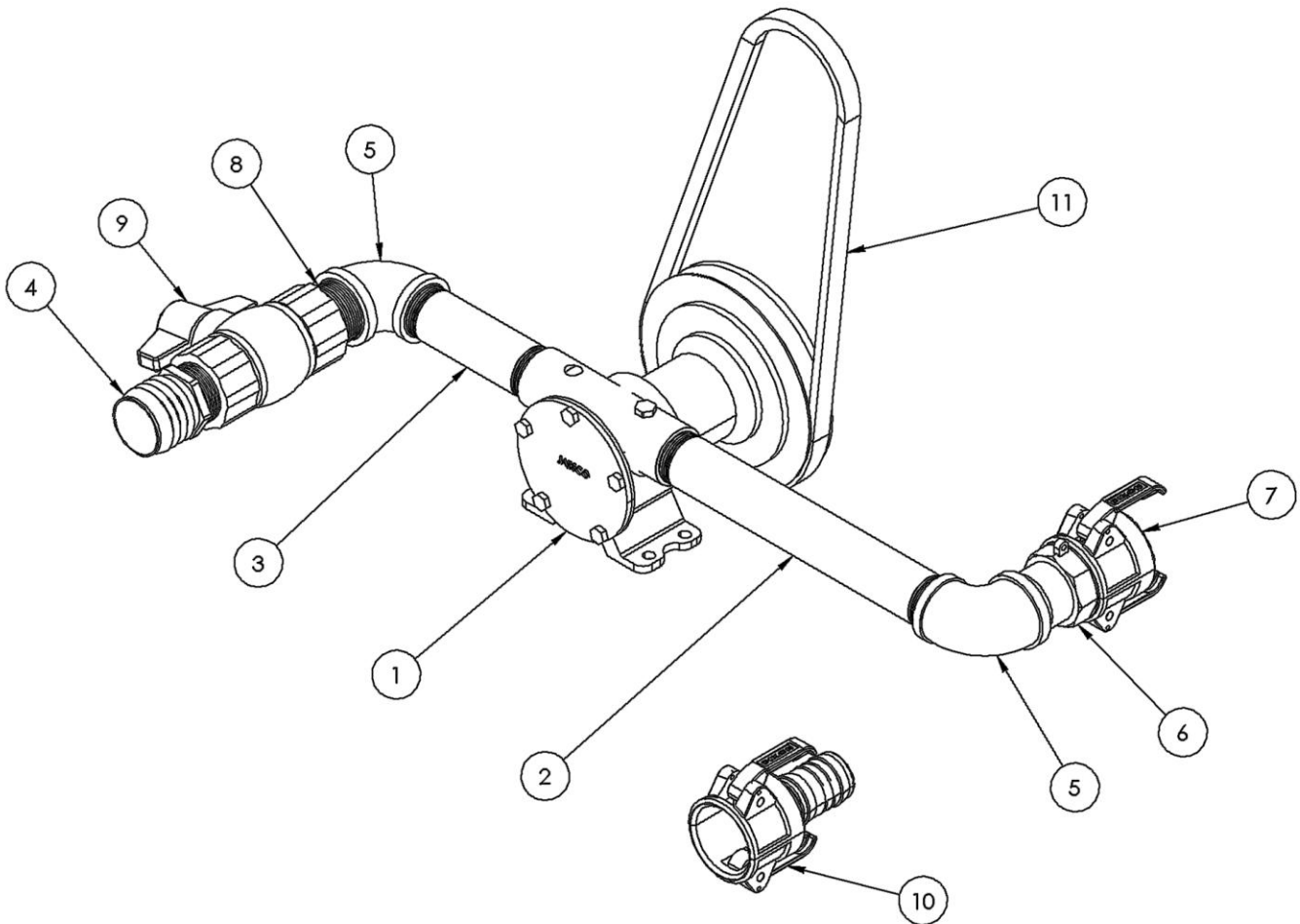

69-388 AUTOMATIC PUMP-OUT

| Item No. | Part Number | Qty | Description |
|----------|-------------|-----|--|
| 1 | 46-054 | 1 | PUMP, JABSCO 1187-0005 |
| 2 | 21-386 | 1 | NIPPLE, 1-1/4 NPT X 12 IN BRASS |
| 3 | 21-337 | 1 | NIPPLE, 1-1/4 NPT X 6 IN BRASS |
| 4 | 21-094 | 1 | FTTG, 1-1/2 P 2 IN H DRAIN |
| 5 | 21-339 | 2 | ELBOW, FEMALE 1-1/2 NPT TO 1-1/4 NPT BRASS |
| 6 | 21-356 | 1 | ADAPTER, 1-1/2 NPT X 1-1/2 CAM & GROOVE |
| 7 | 21-308 | 1 | COUPLING, AL CAP 1-1/2 X 2-1/8 |
| 8 | 21-392 | 1 | NIPPLE, 1-1/2 NPT CLOSE BRASS |
| 9 | 23-022 | 1 | VLV, BALL 1-1/2 FP PVC DUMP |
| 10 | 21-307 | 1 | COUPLING, ALUM LL 1-1/2 X 2-1/8 |
| 11 | 37-084 | 1 | BELT, BX39 GATES COG V |

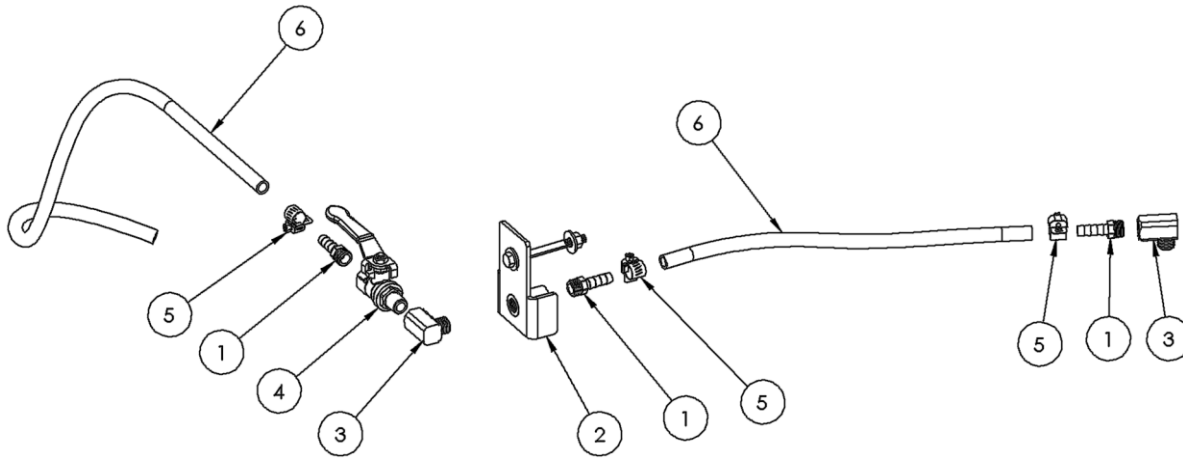

69-333 ASSY, PUMP-OUT ANTIFREEZE KIT

| Item No. | Part Number | Qty | Description |
|----------|-------------|------|----------------------------|
| 1 | 21-006 | 3 | FTTG, BRB 1/4P X 5/16H BR |
| 2 | 61-489 | 1 | WELDMENT, GAS LINE BRACKET |
| 3 | 21-039 | 2 | ELL, 1/4 IN STREET BRASS |
| 4 | 23-071 | 1 | VALVE, BALL 1/4 NPT FXM |
| 5 | 14-007 | 3 | CLAMP, HOSE #4 SS |
| 6 | 16-006 | 3 FT | HOSE, BRAIDED 5/16 ID |

SECTION 4

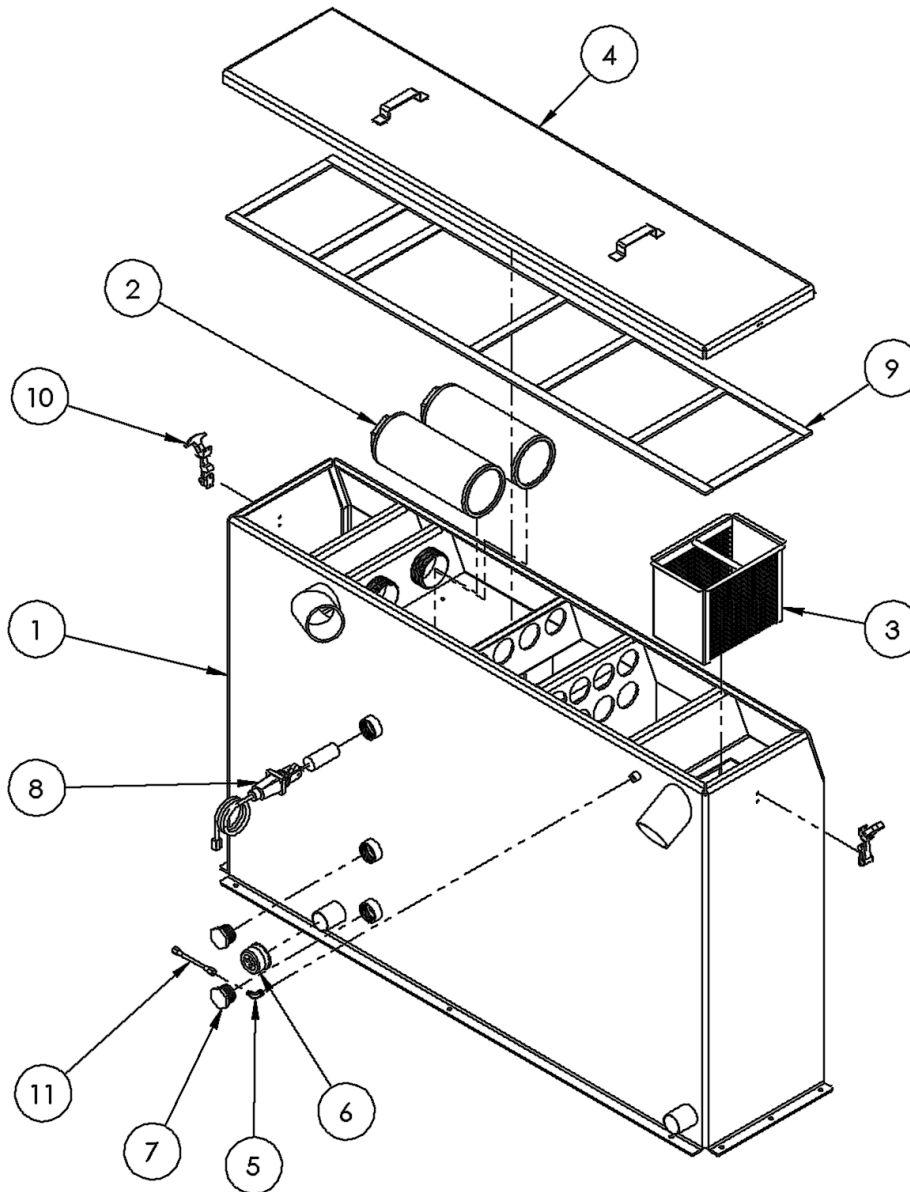

69-298 ASSEMBLY, WASTE TANK

| Item No. | Part Number | Qty | Description |
|----------|-------------|--------|-------------------------------|
| 1 | 61-671 | 1 | WELDMENT, LARGE RECOVERY TANK |
| 2 | 20-021 | 2 | STRAINER, FILTER 3IN 100 MESH |
| 3 | 61-002 | 1 | WELDMENT, STRAINER BASKET |
| 4 | 61-672 | 1 | WELDMENT, LID |
| 5 | 40-003 | 2 | LATCH, PRE-FILTER BOX |
| 6 | 21-064 | 1 | ELL, 1/4P X 1/4T BRASS |
| 7 | 18-215-16 | 1 | HOSE ASSEMBLY, 3/16 ID X 38OL |
| 8 | 19-009 | 1 | CAP, PLUG 2IN RUBBER |
| 9 | 21-097 | 2 | PLUG, 1-1/4 IN PVC |
| 10 | 69-000 | 1 | FLOAT SWITCH |
| 11 | 41-018 | 199 IN | GASKET, SPONGE 11IN X 45FT |



44-084 DECAL,
CAUTION, HOT SURFACE



44-124
DECAL, VAC LUBE



44-080 DECAL,
WARNING, VENTILATED AREA



44-085 DECAL,
WARNING, ROTATING MACHINERY SHOCK



44-067 DECAL,
WARNING READ MANUAL

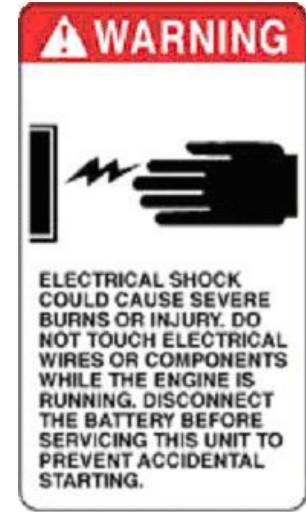

44-066, DECAL
WARNING ELECTRICAL



44-081 DECAL, ENGINE COVER WARRANTY



44-079 DECAL, UNLEADED FUEL ONLY



44-075 DECAL, BIG GULP 3500®

ELECTRICAL DIAGRAM

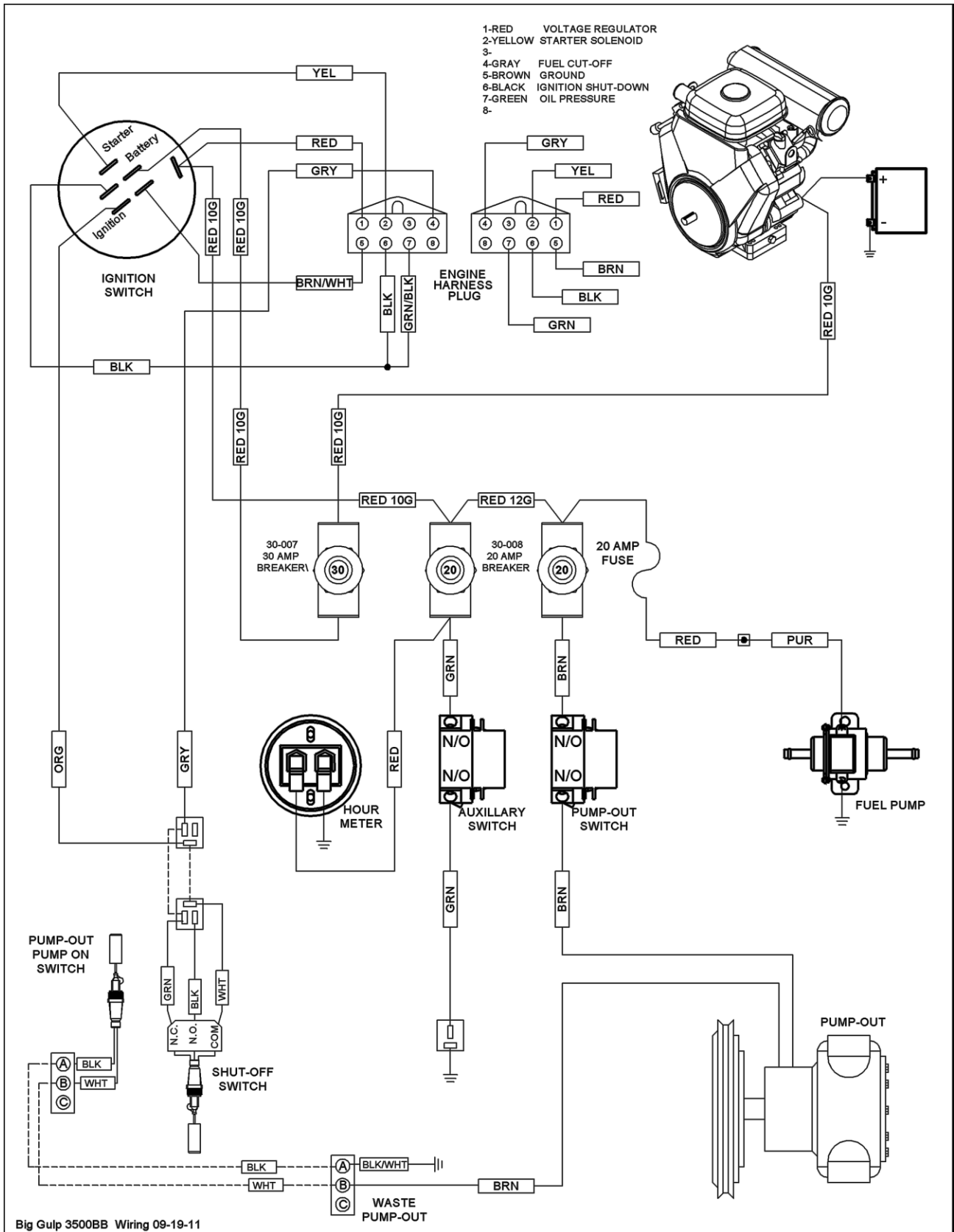

10. ACCESSORIES

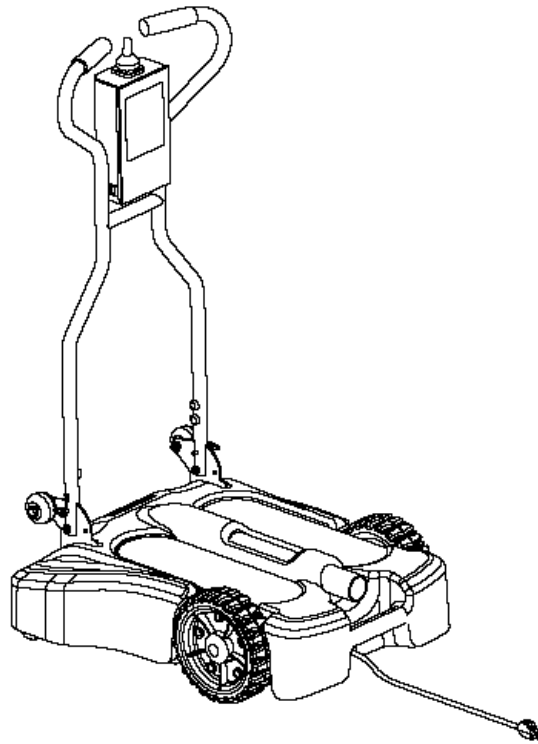

Rover HVE

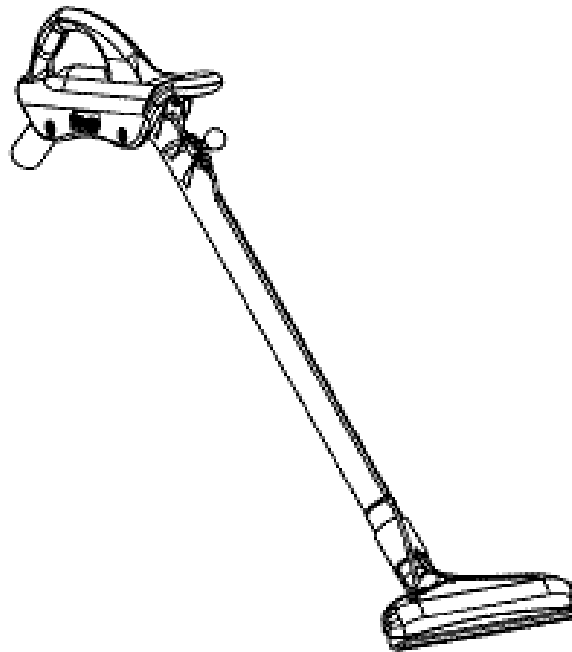

67-014 STRYKER WAND

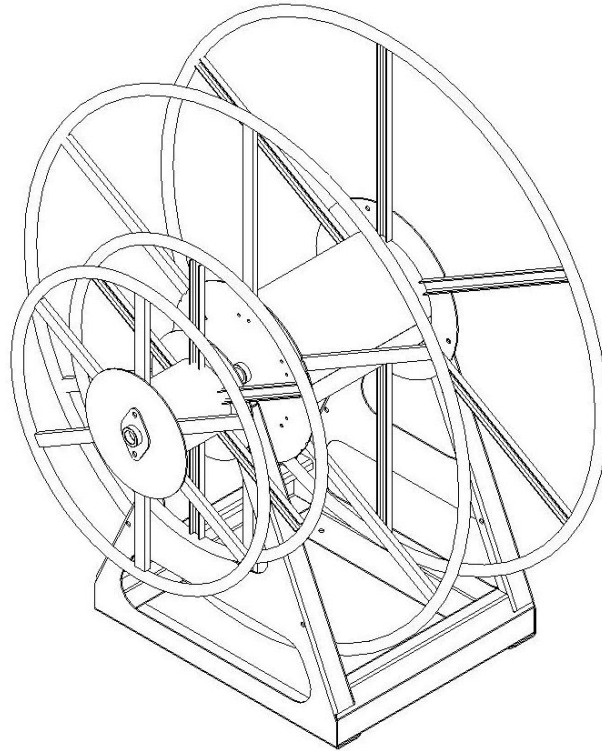

68-025 ASSY, HOSE REEL HIGH PROFILE

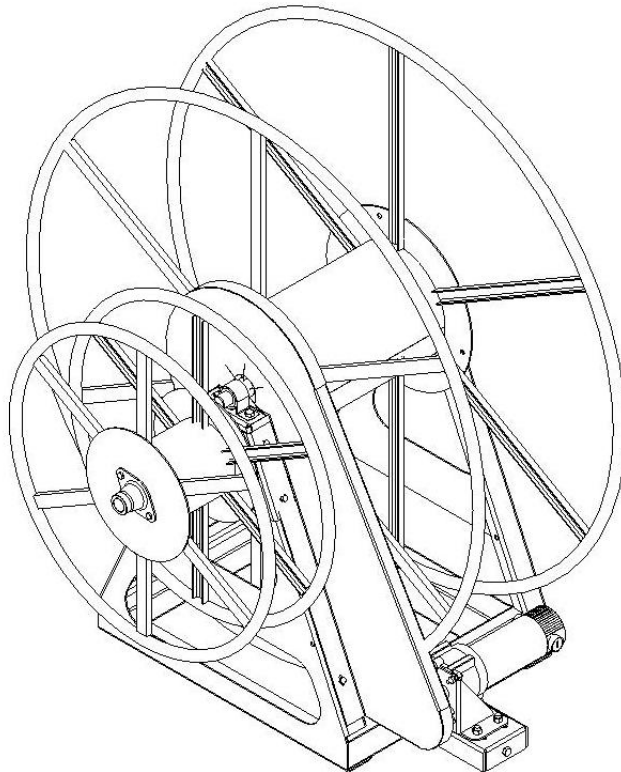

68-033 ASSY, HOSE REEL H. PROFILE W-MTR

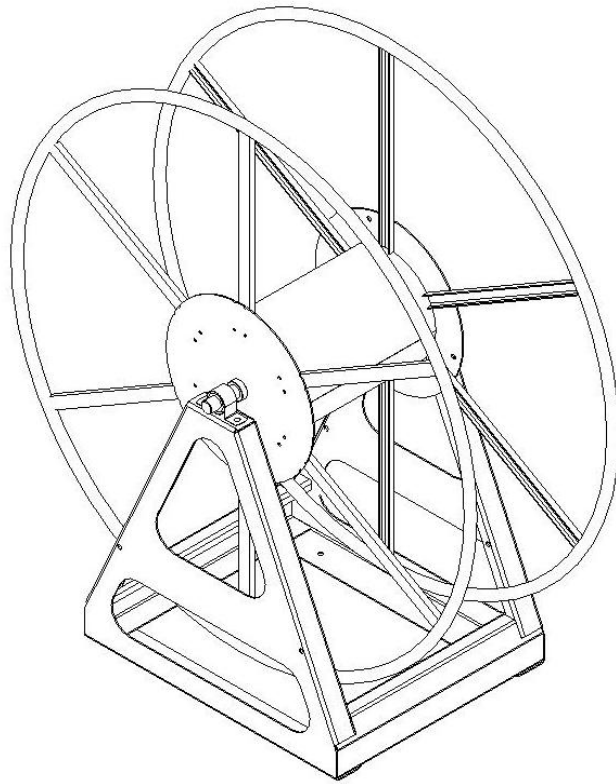

68-037 ASSY, HOSE REEL VAC ONLY

SECTION 4

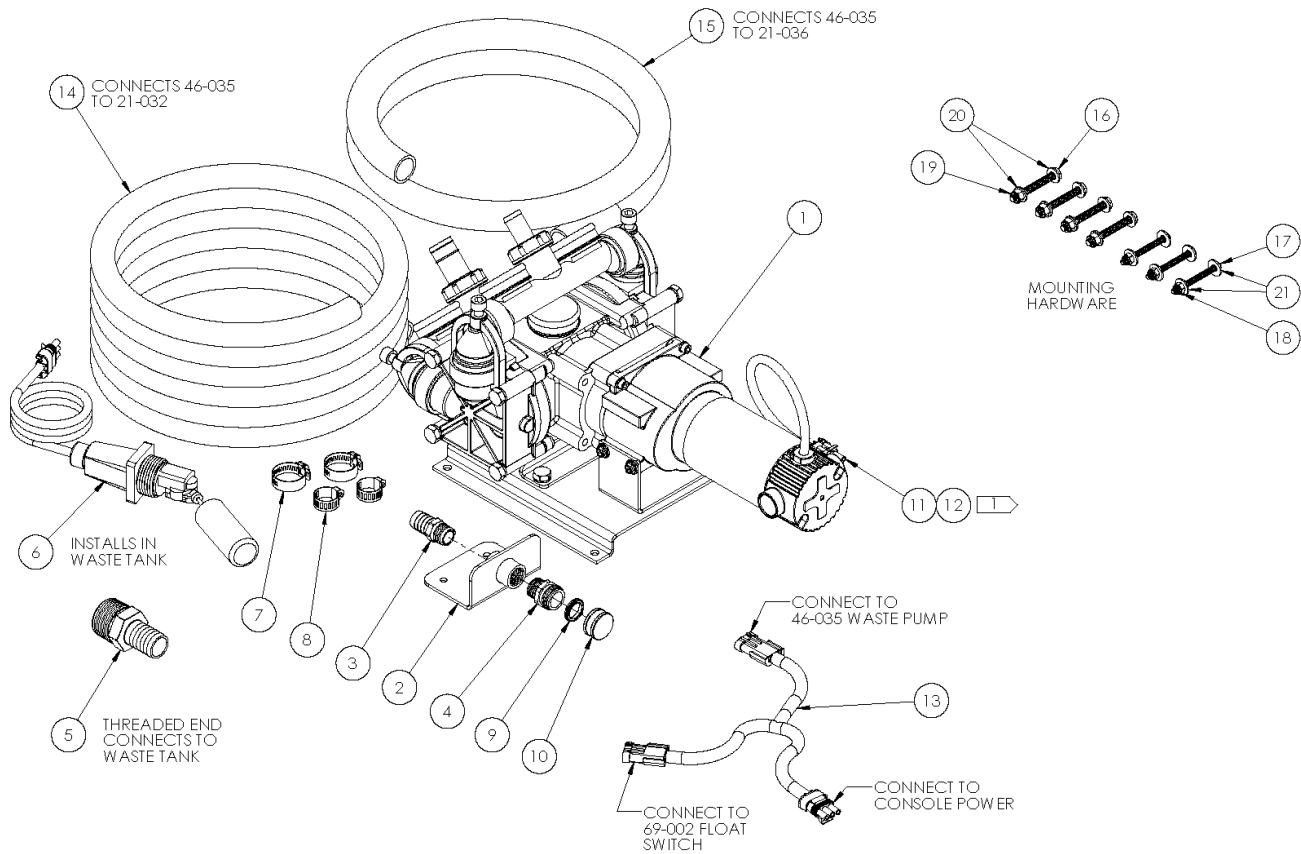

68-158, ASSY, WASTE PUMP OUT

| Item No. | Part Number | Qty | Description |
|----------|-------------|------|------------------------------------|
| 1 | 46-035 | 1 | PUMP, WASTE |
| 2 | 61-656 | 1 | WELDMNT, HOSE BRACKET |
| 3 | 21-032 | 1 | FTTG, BRB 1/2 P X 3/4 H BRASS |
| 4 | 21-398 | 1 | FTTG, GRDN HOSE 1/2 P X 3/4 H |
| 5 | 21-036 | 1 | FTTG, BARB 1-1/4 P X 1 IN BARB |
| 6 | 69-002 | 1 | ASSY, LVL SENSOR SHTOFF WASTE PUMP |
| 7 | 14-006 | 2 | CLAMP, HOSE #20 SS |
| 8 | 14-000 | 2 | CLAMP, HOSE #12 X .5 SS |
| 9 | 41-038 | 1 | WASHER, GARDEN HOSE CAP |
| 10 | 21-071 | 1 | CAP, GARDEN HOSE 3/4 BRASS |
| 11 | 31-016 | 1 | CONN, 3 PRG 1/2 TWR #38045 WAYTEK |
| 12 | 31-019 | 3 | PIN, FEMALE #31035 WAYTEK |
| 13 | 47-031 | 1 | HARNESS, WASTE PUMP OUT |
| 14 | 16-004 | 6 FT | HOSE, WTR 3/4 IN HRZ 500 FT BULK |
| 15 | 16-018 | 2 FT | HOSE, WTR 1 IN HRZ 100 FT BULK |
| 16 | 10-178 | 4 | BOLT, TAP 5/16-18 X 2-1/2 HXHD Z |
| 17 | 10-068 | 3 | BOLT, TAP 1/4-20 X 2-1/2 |
| 18 | 11-013 | 3 | LKNUT, 1/4-20 NYLOK |
| 19 | 11-029 | 4 | NUT, 5/16-18 NYLOK |
| 20 | 12-017 | 8 | WASHER, FLAT 5/16 SAE ZINC |

1992 TO 2002 FORD FUEL LINE INSTALLATION

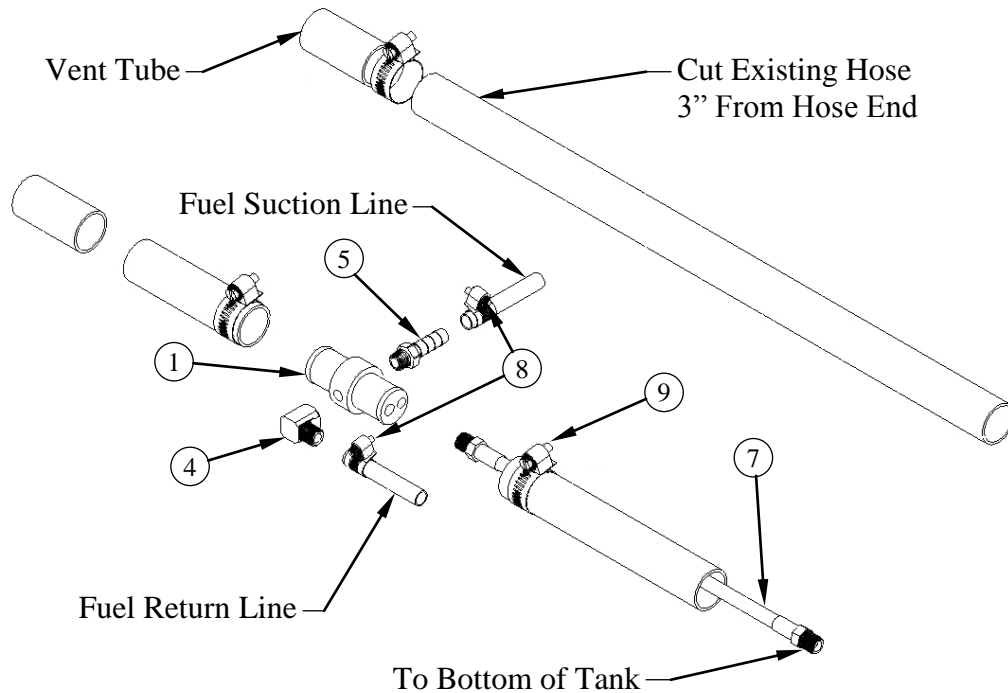

69-005FI KIT, FUEL HOOKUP FORD FI

| Item No. | Part Number | Qty | Description |
|----------|-------------|-----|--|
| 1 | 66-031 | 1 | ADAPTOR, VENT TUBE (FORD) |
| 2 | 21-086 | 2 | FTTG, BULKHEAD 1/4 IN BRASS |
| 3 | 21-039 | 2 | ELL, 1/4 IN LG STREET BRASS |
| 4 | 21-038 | 1 | ELL, STREET 1/8 IN BRASS |
| 5 | 21-007 | 2 | FTTG, BRB 1/8P X 5/16 H BR |
| 6 | 21-006 | 4 | FTTG, BRB 1/4P X 5/16 H BR |
| 7 | 18-028 | 1 | HOSE, 3/16 X 25 (1/8P X 1/8P NO COVER) |
| 8 | 14-011 | 6 | CLAMP, HOSE FUEL # 6 |
| 9 | 14-000 | 2 | CLAMP, HOSE #12 |

CHEVY AND GMC FULL SIZE VAN FUEL LINE INSTALLATION

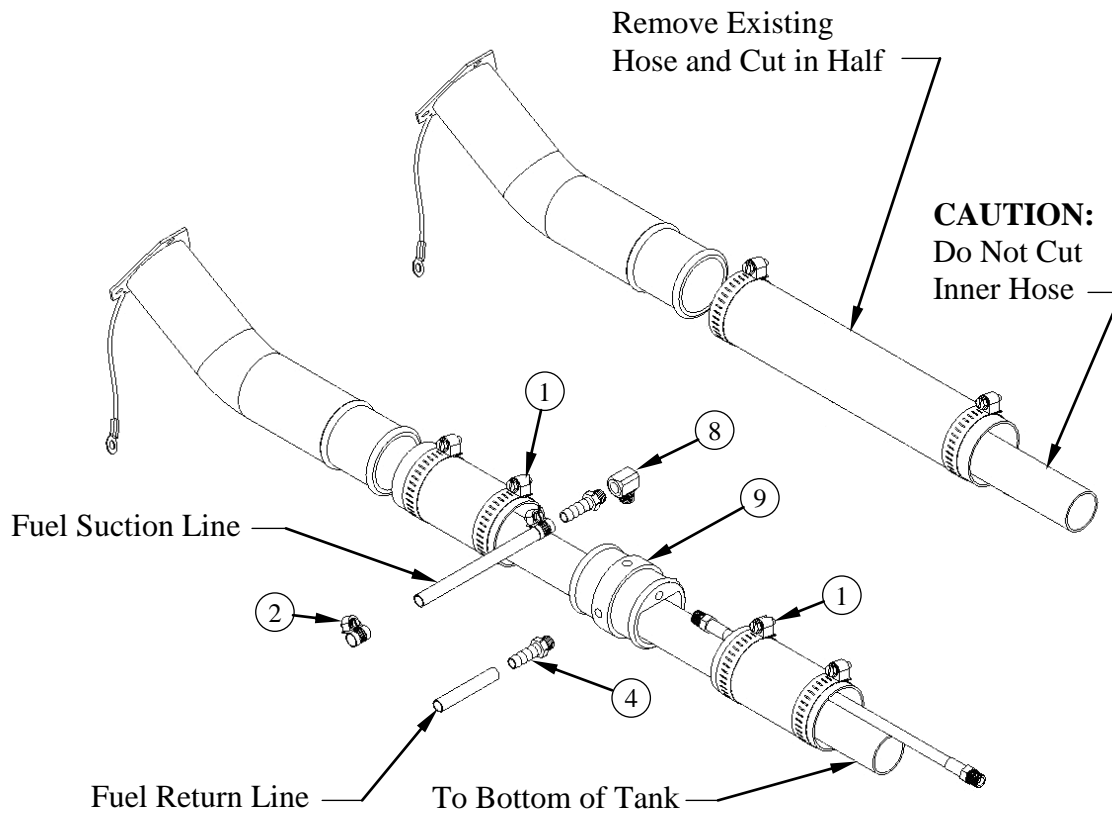

69-003FI KIT, FUEL HOOKUP 97 & 2002 FI

| Item No. | Part Number | Qty | Description |
|----------|-------------|-----|-------------------------------------|
| 1 | 14-010 | 2 | CLAMP, HOSE # 32 |
| 2 | 14-011 | 6 | CLAMP, HOSE FUEL # 6 |
| 3 | 21-006 | 4 | FTTG, BRB 1/4P X 5//16H BR |
| 4 | 21-007 | 2 | FTTG, BRB 1/8P X 5/16 H BR |
| 5 | 21-038 | 1 | ELL, STREET 1/8 IN BRASS |
| 6 | 21-039 | 2 | ELL, 1/4 IN LG STREET BRASS |
| 7 | 21-086 | 2 | FTTG, BULKHEAD 1/4 IN BRASS |
| 8 | 21-116 | 1 | ELL, 1/8 FP X 1/8 FP BRONZE |
| 9 | 66-030 | 1 | ADAPTOR, FUEL NECK (CHEVY) |
| 10 | 18-027 | 2 | HOSE, 3/16 X 5 (1/8P X 1/8P NO CVR) |

SECTION 5

2003 CHEVY AND GMC FULL SIZE VAN FUEL LINE INSTALLATION

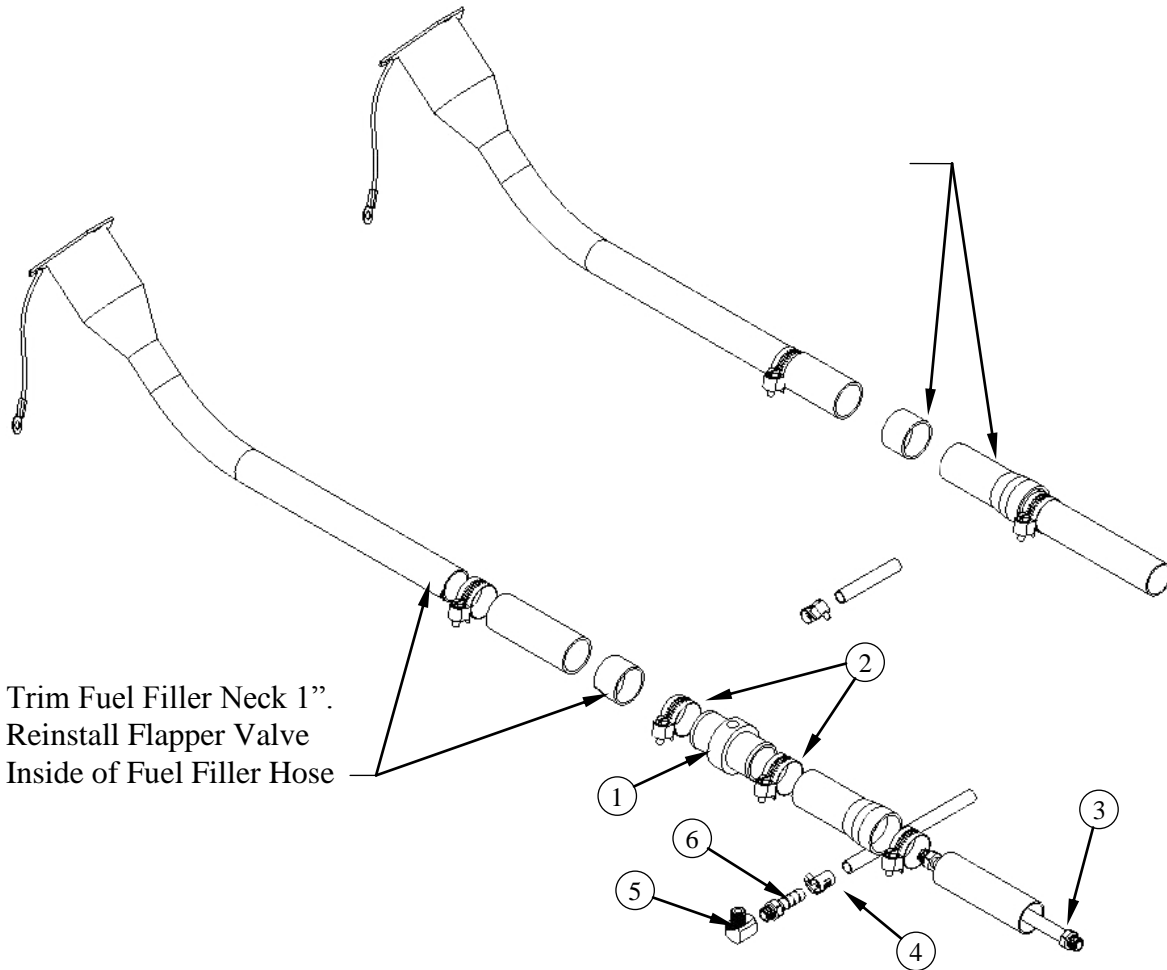

69-018FI KIT, FUEL HOOKUP 2003 CHEVY FI

| Item No. | Part Number | Qty | Description |
|----------|-------------|-----|--|
| 1 | 66-034 | 1 | ADAPTOR, FUEL FLR CHVY 2003 |
| 2 | 14-006 | 2 | CLAMP, HOSE # 20 |
| 3 | 18-028 | 1 | HOSE, 3/16 X 25 (1/8P X 1/8P NO COVER) |
| 4 | 14-011 | 6 | CLAMP, HOSE FUEL # 6 |
| 5 | 21-038 | 1 | ELL, STREET 1/8 IN BRASS |
| 6 | 21-007 | 2 | FTTG, BRB 1/8P X 5/16 H BR |
| 7 | 21-039 | 2 | ELL, 1/4 IN LG STREET BRASS |
| 8 | 21-006 | 4 | FTTG, BRB 1/4P X 5//16H BR |
| 9 | 21-086 | 2 | FTTG, BULKHEAD 1/4 IN BRASS |

1997-2002 DODGE FULL SIZE VAN FUEL LINE INSTALLATION

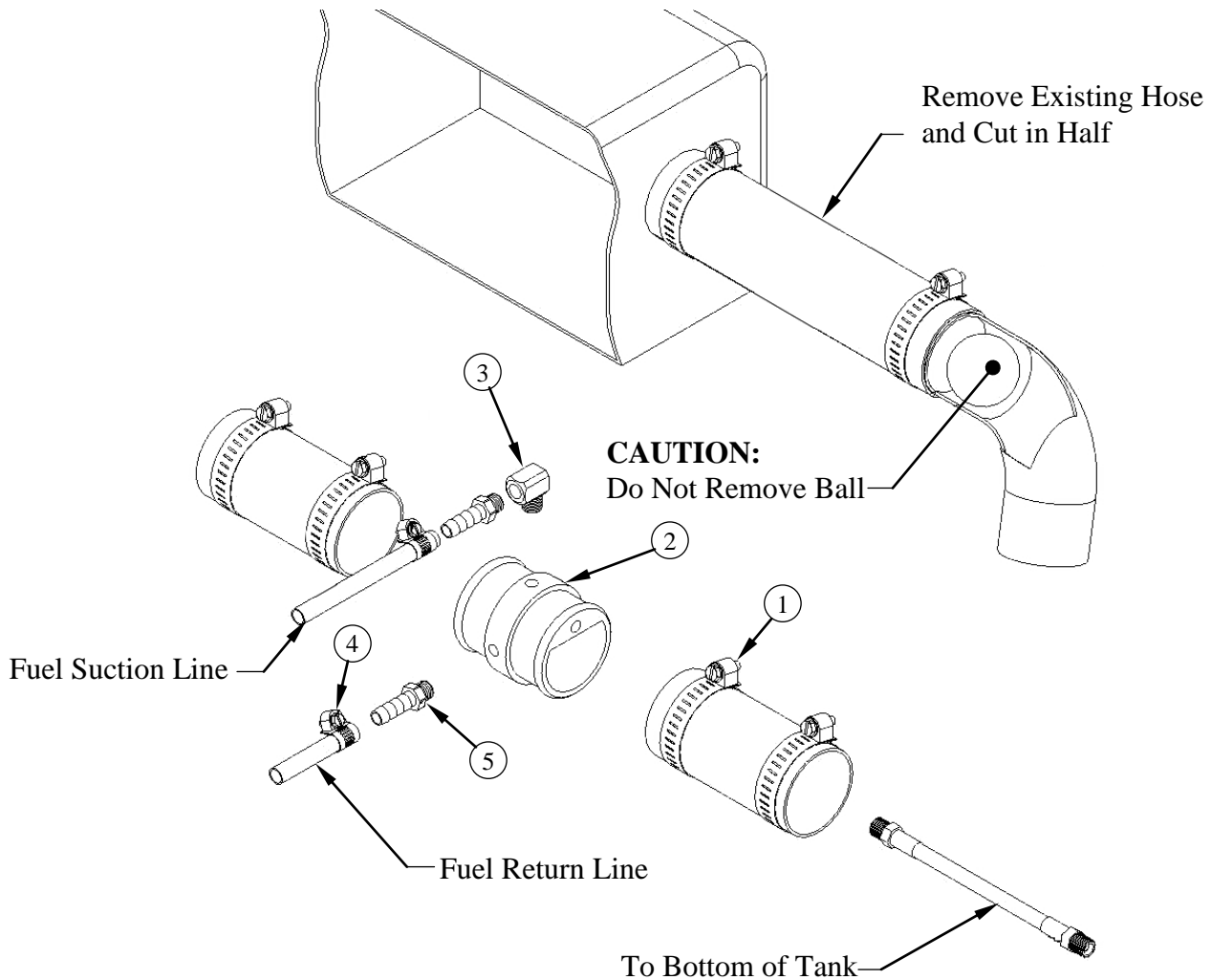

69-004FI KIT, FUEL HOOKUP CHEVY/DODGE

| Item No. | Part Number | Qty | Description |
|----------|-------------|-----|--|
| 1 | 14-010 | 2 | CLAMP, HOSE # 32 |
| 2 | 66-030 | 1 | ADAPTOR,FUEL NECK(CHEVY) |
| 3 | 21-038 | 1 | ELL, STREET 1/8 IN BRASS |
| 4 | 14-011 | 6 | CLAMP, HOSE FUEL # 6 |
| 5 | 21-007 | 2 | FTTG, BRB 1/8P X 5/16 H BR |
| 6 | 18-028 | 1 | HOSE, 3/16 X 25 (1/8P X 1/8P NO COVER) |
| 7 | 21-086 | 2 | FTTG, BULKHEAD 1/4 IN BRASS |
| 8 | 21-006 | 4 | FTTG, BRB 1/4P X 5//16H BR |
| 9 | 21-039 | 2 | ELL,1/4 IN LG STREET BRASS |

Fuel Line Bulkhead Installation (Inside Vehicle)

1. Select an appropriate location on the vehicle floor away from operator or maintenance traffic and away from contact with any accessories or tools while in use or transit. Make sure your hole is within adequate reach of the supplied hose in the finished assembly.
2. Drill a 3/4 inch hole through the vehicle floor at the location chosen for the bulkhead connector.
3. Install the bulkhead connector by inserting the fitting and tightening the nut and lock washer on the opposite side of the vehicle floor.
4. Inside the vehicle, attach the hose barb fitting and connect the fuel line from the console.
5. Drill a 1/2 inch hole nearby the bulkhead fitting for the fuel pump electrical extension harness to pass through.

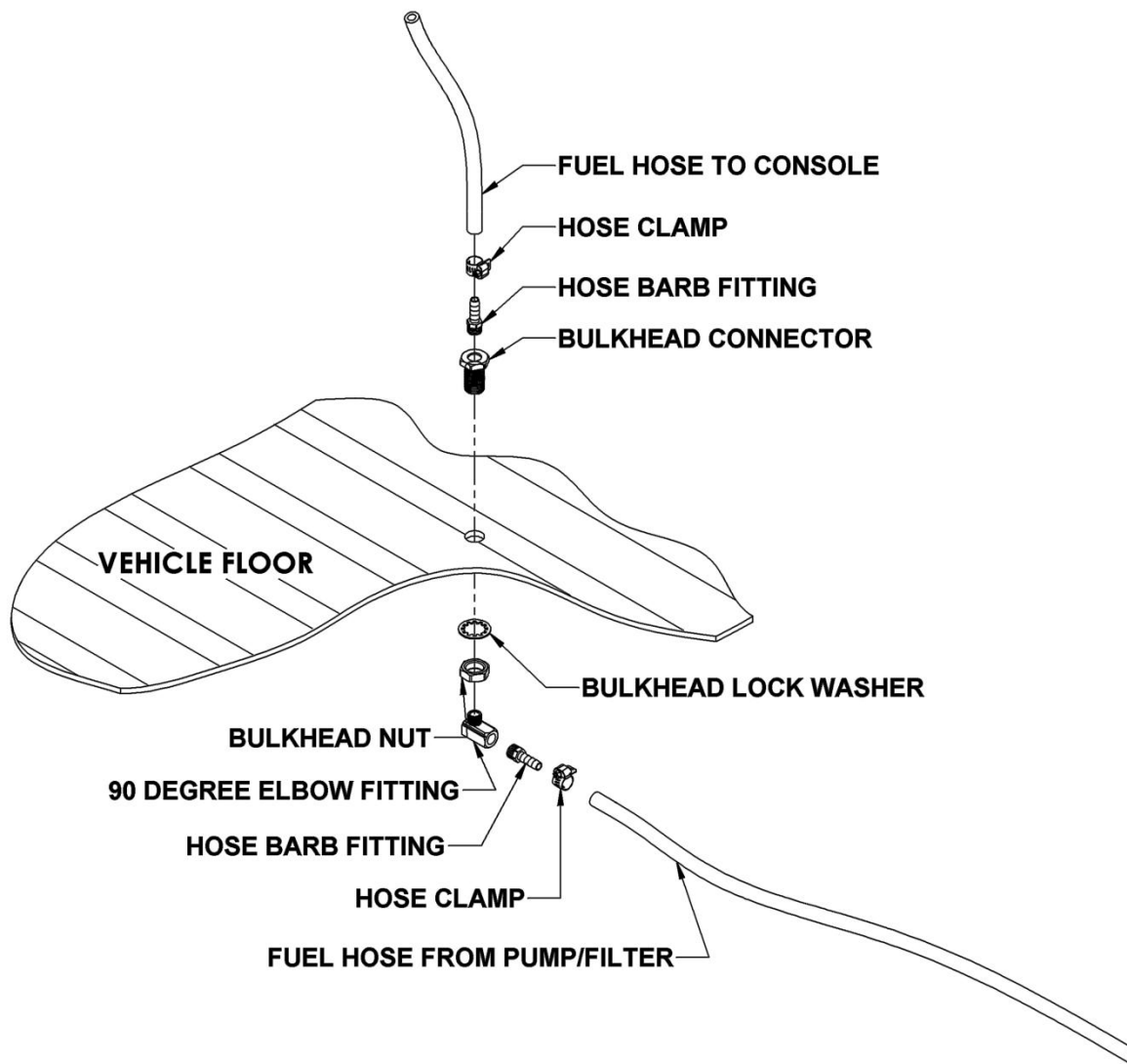

Figure 1. Fuel Line Bulkhead Assembly

Fuel Pump Assembly Installation (Underneath the Vehicle Floor)

1. Locate an appropriate location for the fuel pump assembly housing to mount underneath the vehicle that will not cause damage to the vehicle or compromise the fuel line routing or components.
2. Remove the housing lid from the fuel pump assembly.
3. Use the supplied Tek screws to install the lid of the fuel pump housing to the vehicle.

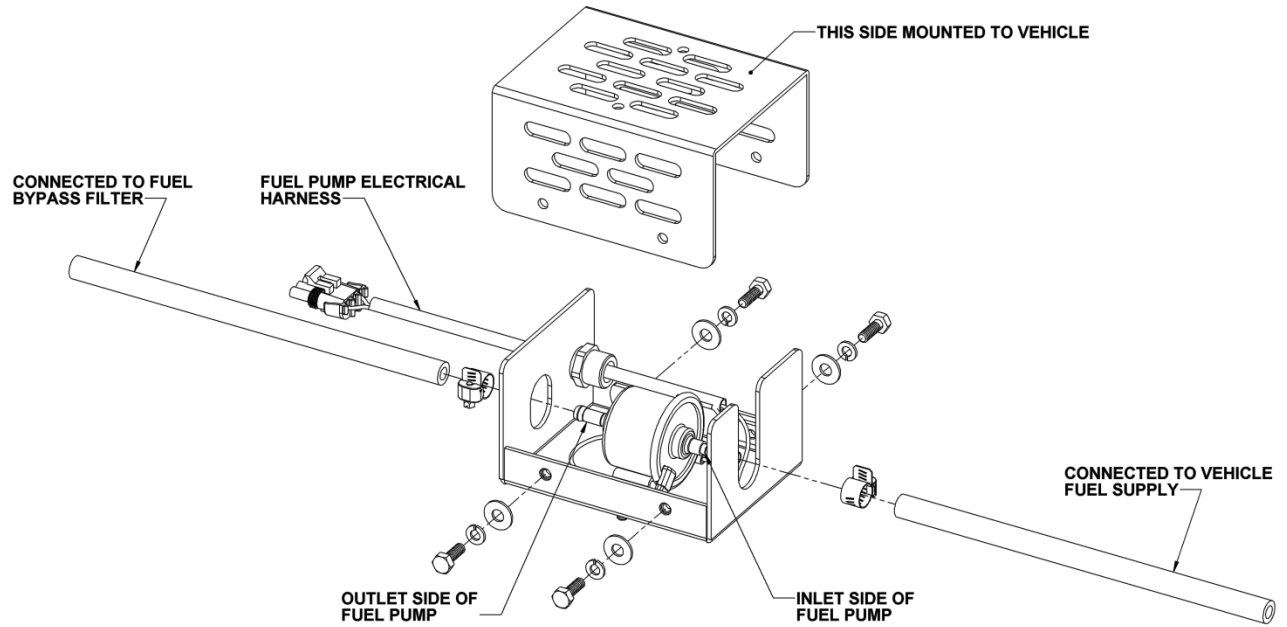

Figure 2. Fuel Pump Assembly Detail

Fuel Supply & Return Line Installation (Underneath the Vehicle Floor)

1. Refer to the transfer flow kit instructions found with the appropriate kit for your vehicle.
2. Connect the fuel line from the transfer flow kit to the inlet side of the fuel pump.
3. Connect the outlet side of the fuel pump to the inlet side of the fuel bypass filter.
4. Connect the return line from the bypass filter return port back to the vehicle fuel supply.

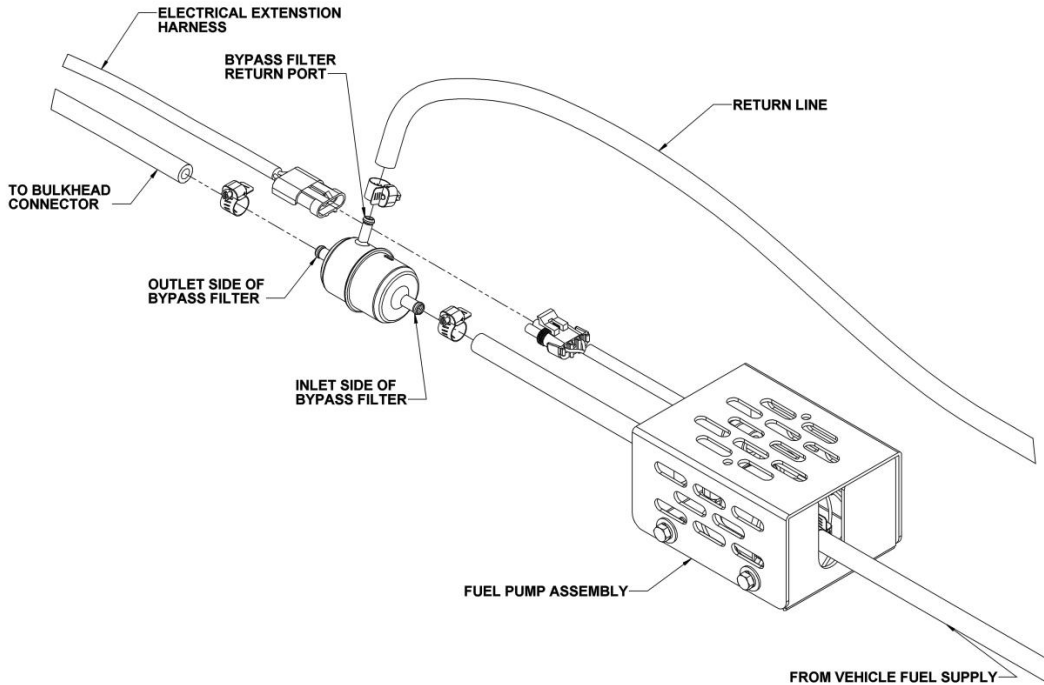

Figure 3. Fuel Pump and Filter Detail

5. Attach the 90 degree elbow and hose barb fittings to the bulkhead connector underneath the vehicle.
6. Connect a segment of hose between the outlet side of the fuel bypass filter to the hose barb fitting.
7. Ensure that all hose clamps are properly tightened.
8. Connect the electrical extension harness to the fuel pump harness, running the other end up through a hole in the floor of the vehicle, connecting to the console harness.

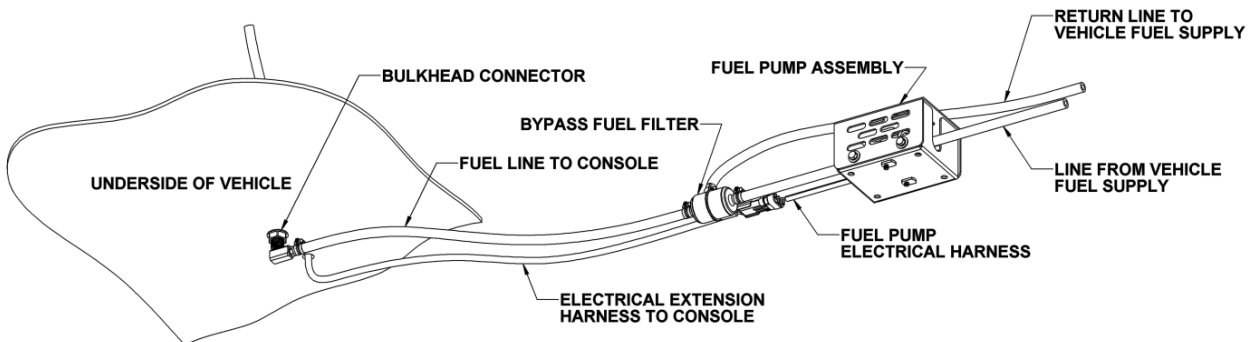

Figure 4. Vehicle Underside Fuel Line Installation